

	GLOBAL STANDARD	Page 1 of 94
	LATTICE STEEL SUPPORTS FOR HIGH VOLTAGE LINES	GSCS001 Rev. 01 05/02/2024

### LATTICE STEEL SUPPORTS FOR HIGH VOLTAGE LINES

Countries I&N	
Argentina	
Brazil	<b>Romulo Alves Moreira Sales</b>
Chile	<b>Daniel Alejandro González Sarkis</b>
Colombia	<b>Juan Carlos Gómez Cubillos</b>
Italy	<b>Giovanni Valtorta</b>
Peru	<b>Roberto Sánchez Vargas</b>
Spain	<b>Maria Avery</b>

	Elaborated by	Verified by	Approved by
Global I&N – O&M/NCS	J.M. Lopez Villena	R. Emma	F. Giammanco

*This document is intellectual property of ENEL Group distribution companies; reproduction or distribution of its contents in any way or by any means whatsoever is subject to the prior approval of the above mentioned companies which will safeguard their rights under the civil and penal codes. This document is for Internal Use.*

Revision	Data	List of modifications
00	09/12/2020	First emission
01	05/02/2024	Italy and Brasil local section added

	GLOBAL STANDARD	Page 2 of 94
	LATTICE STEEL SUPPORTS FOR HIGH VOLTAGE LINES	GSCS001 Rev. 01 05/02/2024

## INDEX

<b>1</b>	<b>SCOPE</b> .....	<b>5</b>
<b>2</b>	<b>LIST OF COMPONENTS</b> .....	<b>5</b>
<b>3</b>	<b>REFERENCE LAWS AND STANDARDS</b> .....	<b>5</b>
<b>3.1</b>	<b>Laws</b> .....	<b>5</b>
<b>3.2</b>	<b>European &amp; International Standards</b> .....	<b>5</b>
<b>3.3</b>	<b>Local Standards</b> .....	<b>6</b>
<b>4</b>	<b>SERVICE CONDITIONS</b> .....	<b>6</b>
<b>5</b>	<b>TECHNICAL CHARACTERISTICS</b> .....	<b>6</b>
<b>5.1</b>	<b>General Characteristics</b> .....	<b>6</b>
<b>5.2</b>	<b>Tower outline and geometry</b> .....	<b>7</b>
<b>5.3</b>	<b>Function</b> .....	<b>8</b>
<b>5.4</b>	<b>Structural Design</b> .....	<b>9</b>
5.4.1	Structural analysis .....	9
5.4.2	Limit Efforts .....	9
5.4.3	Deflection .....	10
<b>5.5</b>	<b>Characteristic Strength</b> .....	<b>10</b>
5.5.1	Standard Loads.....	10
5.5.2	Standard Load Cases .....	11
5.5.3	Security coefficient.....	12
5.5.4	Standard Strength .....	13
5.5.5	Standard Graphs .....	16
<b>5.6</b>	<b>Standard Clearances</b> .....	<b>17</b>

	GLOBAL STANDARD	Page 3 of 94
	LATTICE STEEL SUPPORTS FOR HIGH VOLTAGE LINES	GSCS001 Rev. 01 05/02/2024

5.6.1	Distance between phase conductors .....	17
5.6.2	Distance between phase conductors and earthed parts .....	18
<b>5.7</b>	<b>Standard Height.....</b>	<b>19</b>
<b>5.8</b>	<b>Base Surface .....</b>	<b>19</b>
<b>5.9</b>	<b>Attachment point of conductor and earth wire .....</b>	<b>20</b>
<b>5.10</b>	<b>Maintenance Facilities .....</b>	<b>22</b>
<b>6</b>	<b>DENOMINATION OF SUPPORTS .....</b>	<b>22</b>
<b>6.1</b>	<b>Examples of denomination .....</b>	<b>24</b>
<b>6.2</b>	<b>Example of designation of support .....</b>	<b>25</b>
<b>7</b>	<b>CONSTRUCTION CHARACTERISTICS.....</b>	<b>27</b>
<b>7.1</b>	<b>General Characteristics.....</b>	<b>27</b>
<b>7.2</b>	<b>Materials .....</b>	<b>27</b>
<b>7.3</b>	<b>Welding .....</b>	<b>27</b>
<b>7.4</b>	<b>Connections.....</b>	<b>27</b>
<b>7.5</b>	<b>Anchor Stub.....</b>	<b>28</b>
<b>7.6</b>	<b>Corrosion protection .....</b>	<b>28</b>
<b>8</b>	<b>TESTING .....</b>	<b>28</b>
<b>8.1</b>	<b>Factory acceptance tests .....</b>	<b>28</b>
8.1.1	Visual inspection .....	29
8.1.2	Dimensional verification .....	29
8.1.3	Galvanization verification.....	29
8.1.4	Inspection of welds .....	30
8.1.5	Material properties verification .....	30

	GLOBAL STANDARD	Page 4 of 94
	LATTICE STEEL SUPPORTS FOR HIGH VOLTAGE LINES	GSCS001 Rev. 01 05/02/2024

8.1.6	Weight verification.....	30
<b>8.2</b>	<b>Type test.....</b>	<b>30</b>
<b>9</b>	<b>SUPPLY REQUIREMENTS.....</b>	<b>31</b>
9.1	Packing.....	31
<b>10</b>	<b>DOCUMENTATION.....</b>	<b>32</b>
	<b>LOCAL SECTION A - ENEL DISTRIBUCIÓN COLOMBIA.....</b>	<b>33</b>
	<b>LOCAL SECTION B - ENEL DISTRIBUCIÓN PERÚ.....</b>	<b>34</b>
	<b>LOCAL SECTION C - ENEL DISTRIBUCIÓN CHILE.....</b>	<b>43</b>
	<b>LOCAL SECTION D - ENEL DISTRIBUIÇÃO RIO, CEARÀ AND SÃO PAULO.....</b>	<b>44</b>
	<b>LOCAL SECTION E - E-DISTRIBUZIONE.....</b>	<b>47</b>
	<b>LOCAL SECTION F - EDISTRIBUCIÓN REDES DIGITALES.....</b>	<b>53</b>
	<b>LOCAL SECTION H - EDESUR.....</b>	<b>55</b>
	<b>ANNEX A - STANDARD GRAPHS.....</b>	<b>56</b>
	<b>ANNEX B - LOAD TREES FOR BRAZILIAN TOWERS.....</b>	<b>69</b>
	<b>ANNEX C - LIST OF GLOBAL STANDARD CODES.....</b>	<b>79</b>
	<b>ANNEX D - COMMON LIST OF LOCAL CODES.....</b>	<b>81</b>

	GLOBAL STANDARD	Page 5 of 94
	LATTICE STEEL SUPPORTS FOR HIGH VOLTAGE LINES	GSCS001 Rev. 01 05/02/2024

## 1 SCOPE

The aim of this document is to provide technical requirements for the supply of self-supporting lattice steel supports to be used in high voltage lines with rated voltage above 36 kV of the distribution and transmission networks of Enel Group Distribution Companies, listed below:

<i>Codensa</i>	<i>Colombia</i>
<i>Enel distribución Perú</i>	<i>Perú</i>
<i>Edesur</i>	<i>Argentina</i>
<i>e-distribuzione</i>	<i>Italy</i>
<i>Edistribución Redes Digitales</i>	<i>Spain</i>
<i>Enel distribución Chile</i>	<i>Chile</i>
<i>Enel Distribuição Goiás</i>	<i>Brazil</i>
<i>Enel Distribuição Rio</i>	<i>Brazil</i>
<i>Eletropaulo</i>	<i>Brazil</i>

This standard refers to towers predominantly made of angle members with bolted connections. Nevertheless, some clauses could be applied to other types of towers.

## 2 LIST OF COMPONENTS

The list of components with the main requirements, which is an integral part of the present document, is reported in the common list attached.

## 3 REFERENCE LAWS AND STANDARDS

The list of reference laws and standards are mentioned below in this document.

### 3.1 Laws

R.D. 223/2008 Reglamento sobre condiciones técnicas y garantías de seguridad en líneas eléctricas de alta tensión.

R.P.C. 305/2011 Reglamento europeo de productos de la construcción.

ITC-LAT-07 Instrucción Técnica Complementaria del Reglamento sobre condiciones técnicas y garantías de seguridad en líneas eléctricas de alta tensión.

### 3.2 European & International Standards

EN 1090 Ejecución de estructuras de acero y aluminio.

EN 1992 Eurocódigo 2: Proyecto de estructuras de hormigón.

	GLOBAL STANDARD	Page 6 of 94
	LATTICE STEEL SUPPORTS FOR HIGH VOLTAGE LINES	GSCS001 Rev. 01 05/02/2024

EN 1993	Eurocódigo 3: Proyecto de estructuras de acero.
EN 10025	Productos laminados en caliente de aceros para estructuras
EN 10056	Angulares de lados iguales y desiguales de acero estructural
EN 10149	Productos planos laminados en caliente de acero de alto límite elástico para conformado en frío.
EN 50341	Overhead electrical lines exceeding AC 1 kV
EN 60652	Ensayos mecánicos de estructuras para líneas eléctricas aéreas.
EN 60865	Corrientes de cortocircuito. Cálculo de efectos.
EN 61773	Líneas aéreas. Ensayos de cimentaciones de estructuras.
ISO 1461	Recubrimientos de galvanización en caliente sobre piezas de hierro y acero. Especificaciones y métodos de ensayo.
ISO 17025	Evaluación de la conformidad. Requisitos generales para la competencia de los laboratorios de ensayo y de calibración.
UNE-17115:2010	Elementos de fijación. Conjuntos de tornillo, tuerca y arandela para uso en apoyos metálicos para líneas eléctricas aéreas. Características dimensionales y mecánicas.
ASCE 10-15	Design of Latticed Steel Transmission Structures
IEC 60826:2017	Design criteria of overhead transmission lines
EN ISO 6892-1:2019	Metallic materials. Tensile testing. Part 1: Method of test at room temperature.

### 3.3 Local Standards

See Local Section.

## 4 SERVICE CONDITIONS

These structures are intended for use in electrical networks with nominal tension from 45 kV to 220 kV.

## 5 TECHNICAL CHARACTERISTICS

### 5.1 General Characteristics

Latticed steel towers must hold conductors and ground wires of lines in such a way that electrical and mechanical requirements are met with acceptable levels of reliability and with due regard to safety of the public, durability, maintainability and appearance.

The above requirements shall take account environmental scenarios sufficiently severe to encompass all conditions which can be foreseen to occur during the working life of the towers.

They shall be designed to avoid human injuries or loss of life during installation and maintenance operations.

	GLOBAL STANDARD	Page 7 of 94
	LATTICE STEEL SUPPORTS FOR HIGH VOLTAGE LINES	GSCS001 Rev. 01 05/02/2024

Towers will mainly hold one or two circuits and their corresponding earth wires, although they could hold more than these in case of necessity.

### 5.2 Tower outline and geometry

Depending the number of crossarms for conductors and earth wires and their disposition on the support there could be different configurations that form the outline of the tower.

The most usual are those indicated below:

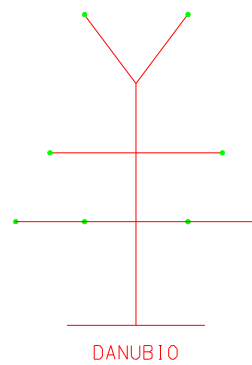
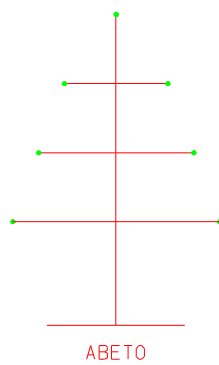
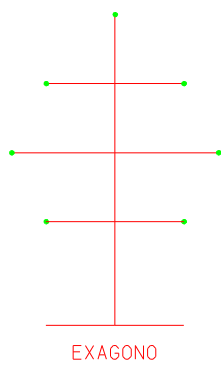
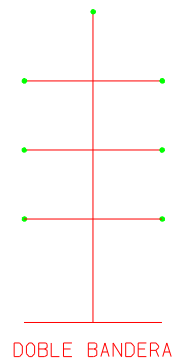
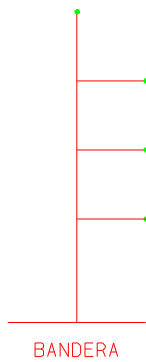
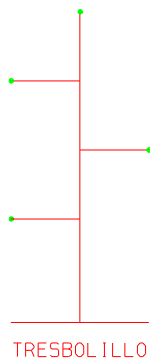

	GLOBAL STANDARD	Page 8 of 94
	LATTICE STEEL SUPPORTS FOR HIGH VOLTAGE LINES	GSCS001 Rev. 01 05/02/2024

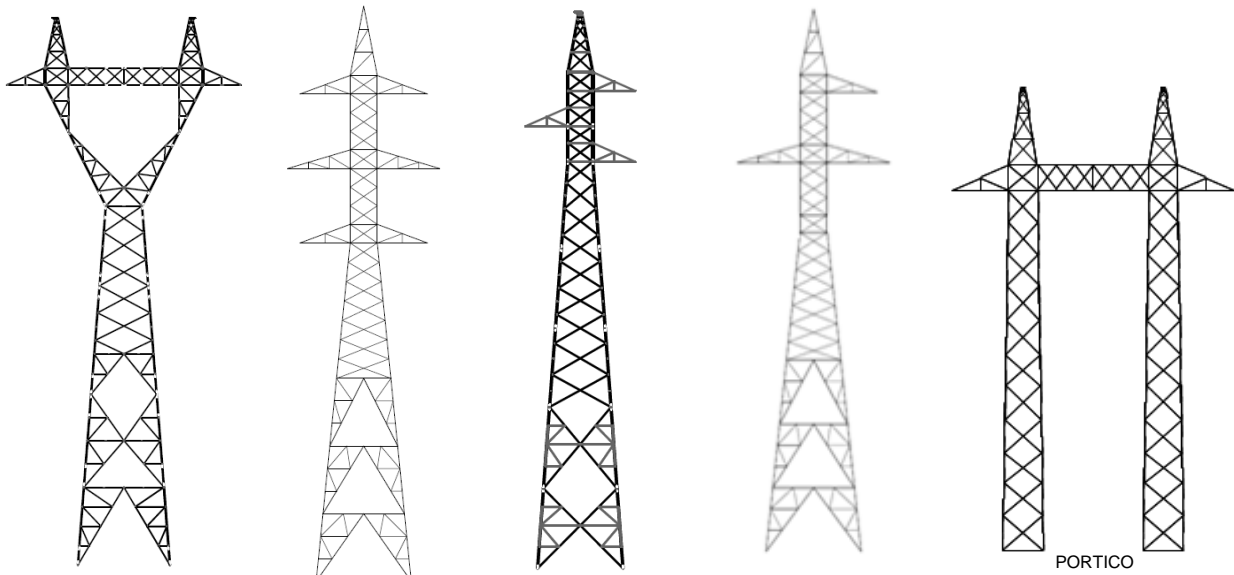
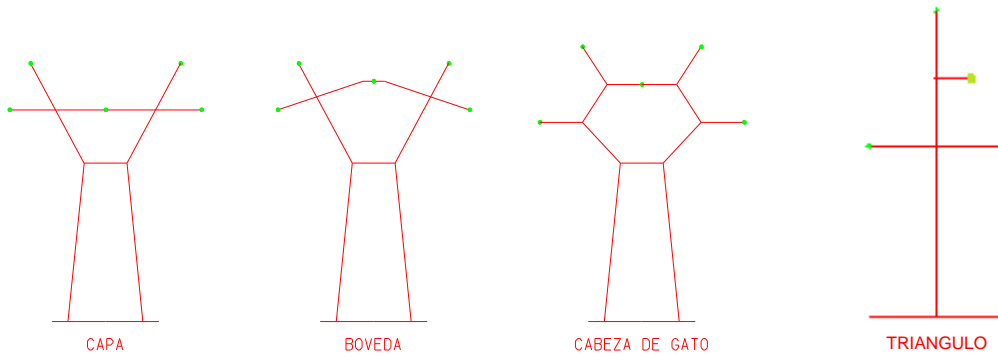

The standard configurations used on Enel distributions companies are the following:

- For single circuit: Tresbolillo
- For double circuit: Doble bandera.

Any other configuration must be indicated explicitly.

### 5.3 Function

According to the function in the line, towers can be classified as follows:

- L-Suspension: Tower with vertical insulation chains.
- M-Tension: Tower with horizontal insulation chains.
- G-Anchorage: Tension tower intended to provide a strong point along the line to avoid a progressive collapse (cascading).



	GLOBAL STANDARD	Page 9 of 94
	LATTICE STEEL SUPPORTS FOR HIGH VOLTAGE LINES	GSCS001 Rev. 01 05/02/2024

- F-Terminal or end of line: The first and last tension towers of the line, which support longitudinally all the mechanical load of every conductor.
- Special: Towers with a function different to the previously indicated such as derivations, conversions to underground lines, etc.

According to the position in the line, towers can be classified as follows:

- Angle Tower: There is a change in line direction.
- Alignment Tower: There is not a change in line direction.

#### 5.4 Structural Design

Structural design of towers shall meet requirements of EN-50341-1 or ASCE 10-15.

At all crossarm levels and at changes of slope of leg members, horizontal bracings shall be provided, and the adequacy of their strength shall be proven.

The towers will be designed so that all parts are accessible for inspection and cleaning. Pockets or depressions that could store water should have drainage holes.

For all members which can be climbed and are inclined with an angle less than 30° to the horizontal, a load of 200 daN acting vertically in the centre of the member shall be assumed without any other loads.

The eccentricity of the connections of members at nodes shall be kept as small as possible.

##### 5.4.1 Structural analysis

Supports are structures with some degree of hyperstaticity and their final calculated strength can be influenced by structure modelling.

Usually latticed steel towers are considered as pin jointed truss and beam structures. It can be assumed that enough precision is achieved when it is used a spatial model where the main bars and all bars that have “plain nodes” are modelled with beam elements and all the other with truss elements.

The internal forces and moments shall be determined using elastic global analysis, on the assumption that the stress-strain behaviour of the material is linear, irrespective of the stress level and may generally be determined using first order theory.

Concentrated loads must be considered applied at the attachment point.

Superficial or volumetric loads could be considered applied at all nodes of the model.

##### 5.4.2 Limit Efforts

The limit stress of each angle element of the tower structure will be:

- For tensile stresses: The elastic limit of steel.
- For compression stresses: The buckling limit stress.

The slenderness ratio of elements to compression, as defined on ASCE 10-95, shall not exceed the following limits:

	GLOBAL STANDARD	Page 10 of 94
	LATTICE STEEL SUPPORTS FOR HIGH VOLTAGE LINES	GSCS001 Rev. 01 05/02/2024

- For studs and crosspieces :150
- For braces, diagonals and other elements :200
- For redundant elements :250

#### 5.4.3 Deflection

In any condition of use not exceptional and loads applied without overload factors, the maximum displacement at any point of the support calculation model may not exceed the following values:

- 1/30 times the maximum height of the support on the ground for supports type L.
- 1/50 times the maximum height of the support on the ground for the rest of the supports.

### 5.5 Characteristic Strength

The strength of a support under a defined set of loads is determined by the strength of the element that first reach its damage limit under that set of loads. So, the total strength of a supports is related to the combination of loads resisted in every circumstance. Every set of loads is called a Load Case and there is a characteristic strength for a support in every Load Case.

The set of all characteristic strengths of one support for every load case considered is the characteristic strength that define this support.

#### 5.5.1 Standard Loads

The loads involved in the determination of the support strength are the following:

- Loads transmitted by conductors and earth wires to the cross-arms at their attachment point. In case of conductor at the attachment point of the insulators that supports them.  
On a tower with N attachment point for conductors and  $N_e$  attachment point for earth wires, those loads will be named like this:
  - $L_i$ : Load transmitted by conductors to attachment point number i in the line direction (perpendicularly to the cross-arm).
  - $T_i$ : Load transmitted by conductors to attachment point number i transverse to the direction of the line (parallel to the cross-arm)
  - $V_i$ : Load transmitted by conductors to attachment point number i in vertical direction.
  - $L_{ei}$ : Load transmitted by earth wires to attachment point number ei in the line direction (same direction than  $L_i$ ).
  - $T_{ei}$ : Load transmitted by earth wires to attachment point number ei transverse to the direction of the line same direction than  $T_i$ ).
  - $V_{ei}$ : Load transmitted by earth wires to attachment point number ei in vertical direction.

	GLOBAL STANDARD	Page 11 of 94
	LATTICE STEEL SUPPORTS FOR HIGH VOLTAGE LINES	GSCS001 Rev. 01 05/02/2024

- Pressure loads due to wind acting on the tower itself, supported over the surface of every exposed element of the support.

For structural analysis purpose, these loads could be considered as concentrated loads acting on the nodes of the towers. In any case, the sum of all these loads have to be equal or greater than the product of the wind pressure considered and the total area resulting from the projection of every element of the support (including cross-arms, plates, etc... ) on a plane perpendicular to the wind direction.

- Own weight of support.

Unless otherwise specified, it is not necessary to consider seismic effects or fire resistance.

### 5.5.2 Standard Load Cases

The loads cases to consider in order to define the characteristic strength of a supports are these:

- Load Case 1: This case is useful to define the characteristic strength of a supports when pressure loads, like those of wind, are acting on the tower itself. Loads considered in this case are:
  - Own weight of support.
  - Wind pressure on the tower itself equal to 170 daN/m<sup>2</sup>. (120 km/h)
  - Loads  $L_i$ ,  $T_i$  and  $V_i$  equals in every attachment point for conductors.
  - Loads  $L_{ei}$ ,  $T_{ei}$  and  $V_{ei}$  equals in every attachment point for earth wires.
- Load Case 2: In this case there are not pressure loads on the tower itself. It is useful to represent cases of unbalanced span's tension, ice on conductors or any other situation where the loads supported at all attachment points for conductors are equals and all loads supported at attachment points for earth wires are equal too. Loads considered are:
  - Own weight of support.
  - Loads  $L_i$ ,  $T_i$  and  $V_i$  equals in every attachment point for conductors.
  - Loads  $L_{ei}$ ,  $T_{ei}$  and  $V_{ei}$  equals in every attachment point for earth wires.
- Load Case 3: In this case the load at one attachment point of conductors is different from the others. It is useful to represent the breaking of a conductor. Loads considered are:
  - Own weight of support.
  - Loads  $L_R$ ,  $T_R$  and  $V_R$  in one of the attachment points for conductors (R), the most unfavorable for the strength of the support.
  - Loads  $L_i$ ,  $T_i$  and  $V_i$  equals in all the rest of the attachment points for conductors different from R.
  - Loads  $L_{ei}$ ,  $T_{ei}$  and  $V_{ei}$  equals in every attachment point for earth wire.
- Load Case 3F (break of conductor for a support with end of line function):

	GLOBAL STANDARD	Page 12 of 94
	LATTICE STEEL SUPPORTS FOR HIGH VOLTAGE LINES	GSCS001 Rev. 01 05/02/2024

- Own weight of support.
- Loads  $L_R$ ,  $T_R$  and  $V_R$  equals to zero in one of the conductors, the most unfavorable for the strength of the support.
- Loads  $L_i$ ,  $T_i$  and  $V_i$  equals in all the rest of the conductors different from conductor R.
- Loads  $L_{ei}$ ,  $T_{ei}$  and  $V_{ei}$  equals in every earth wire.
- Load Case 4 (break of earth wire): In this case the load at one attachment point of earth wires is different from the others. It is similar to Case 3 but represent the breaking of an earth wire instead of a conductor. Loads considered are:
  - Own weight of support.
  - Loads  $L_i$ ,  $T_i$  and  $V_i$  equals in all the attachment point of conductors.
  - Loads  $L_{eR}$ ,  $T_{eR}$  and  $V_{eR}$  in one of the attachment points for earth wires. The most unfavorable for the strength of the support in case that there are more than one earth wire.
  - Loads  $L_{ei}$ ,  $T_{ei}$  and  $V_{ei}$  equals in all the others attachment points for earth wires, in case there are more than one.
- Load Case 4F (break of earth wire for a support with end of line function):
  - Own weight of support.
  - Loads  $L_i$ ,  $T_i$  and  $V_i$  equals in all the conductors.
  - Loads  $L_{eR}$ ,  $T_{eR}$  and  $V_{eR}$  equals to zero in one of the earth wire. The most unfavorable for the strength of the support in case that there is more than one earth wire.
  - Loads  $L_{ei}$ ,  $T_{ei}$  and  $V_{ei}$  equals in all the others earth wires, in case that there is more than one earth wire.
- Load Case 5: This case represents the characteristic strength of a support with a special function as derivation. Loads considered in this case are:
  - Own weight of support.
  - Wind pressure on the tower itself equal to 170 daN/m<sup>2</sup>. (120 km/h)
  - Loads  $L_{iR}$ ,  $T_{iR}$  and  $V_{iR}$  equals in every attachment point for conductors on the right side of the tower.
  - Loads  $L_{iL}$ ,  $T_{iL}$  and  $V_{iL}$  equals in every attachment point for conductors on the left side of the tower.
  - Loads  $L_{eiR}$ ,  $T_{eiR}$  and  $V_{eiR}$  for an earth wire on the right side of the tower.
  - Loads  $L_{eiL}$ ,  $T_{eiL}$  and  $V_{eiL}$  for an earth wire on the left side of the tower.

### 5.5.3 Security coefficient

For every load case the security coefficient of one support is defined by the lower security coefficient of any element of this support, including angles, bolts, plates, etc...

The security coefficient of that element is defined as

$$CS = E_i / R_i$$

where

$E_i$  is the value of the effect of actions (Load Cases), such as internal force or moment, or a representative vector of several internal forces or moments on the element

$R_i$  is the corresponding structural resistance for that element.

#### 5.5.4 Standard Strength

The standard strength of a support is defined by a set of minimum actions that must be able to resist for each load case with a defined security coefficient. So, every standard strength could be represented as a set of loading trees, where on every crossarm are acting the loads  $L_i$ ,  $T_i$  and  $V_i$  and on every point of attachment of the earth wire are acting the loads  $L_{ei}$ ,  $T_{ei}$  and  $V_{ei}$  defined on every load case.

The values of those actions and security coefficients are contemplated in the tables below.

Standard Strength	Load Case 1 and CS = 1,5					
	Load for every crossarm (daN)			Load for every earth wire (daN)		
	$L_i$	$T_i$	$V_i$	$L_{ei}$	$T_{ei}$	$V_{ei}$
L-0	-	264	250	-	251	220
L-1	-	531	500	-	366	435
L-2	-	620	1.212	-	415	497
L-3	-	1.490	1.715	-	1.103	1.612
M-0	-	820	600	-	599	528
M-1	-	1.100	1.120	-	748	706
M-2	-	1.300	1.290	-	1.105	1.187
M-3	-	1.600	1.855	-	1.104	1.762
M-4	-	1.810	3.735	-	1.104	2.092
G-1	-	2.485	1.100	-	1.988	1.001
G-2	-	2.930	1.290	-	2.491	1.187
G-3	-	3.460	1.365	-	2.491	1.269
G-5	-	4.080	2.850	-	2.489	2.109
G-6	-	6570	2780	-	2497	2113
F-1	2.698	382	857	2.374	378	754
F-2	3.826	589	1.002	2.372	530	902
F-3	3.877	1.013	1.895	2.404	932	1.800
F-4	3.575	3.000	1.520	1.788	1140	1.186
F-5	4.775	3.780	1.520	2.388	1021	1.186



Load Case 1 and CS = 1,875						
Standard Strength	Load for every crossarm (daN)			Load for every earth wire (daN)		
	Li	Ti	Vi	Lei	Tei	VeI
L-0	-	200	200	-	190	176
L-1	-	390	400	-	269	348
L-2	-	465	970	-	312	398
L-3	-	1.135	1.370	-	840	1.288
M-0	-	640	480	-	467	422
M-1	-	820	890	-	558	561
M-2	-	1.025	1.030	-	871	948
M-3	-	1.220	1.480	-	842	1.406
M-4	-	1.380	2.980	-	842	1.669
G-1	-	1.950	880	-	1.560	801
G-2	-	2.290	1.030	-	1.947	948
G-3	-	2.780	1.090	-	2.002	1.014
G-5	-	3.200	2.280	-	1.952	1.687
G-6	-	5140	2220	-	1957	1687
F-1	1.140	1.118	680	1.003	1.106	598
F-2	3.040	500	800	1.885	450	720
F-3	3.200	750	1.515	1.984	690	1.439
F-4	2.630	2.325	1.215	1.315	884	948
F-5	3.315	3.100	1.215	1.658	837	948

Load Case 2 and CS = 1,2						
Standard Strength	Load for every crossarm (daN)			Load for every earth wire (daN)		
	Li	Ti	Vi	Lei	Tei	VeI
L-0	330	-	250	1000	-	220
L-1	664	-	500	1069	-	435
L-2	775	-	1.212	1372	-	1091
L-3	1863	-	1.715	1379	-	1.612
M-0	1025	-	600	1005	-	528
M-1	1375	-	1.120	1375	-	1019
M-2	1625	-	1.290	1381	-	1.187
M-3	2000	-	1.855	1380	-	1.762
M-4	2263	-	3.735	1380	-	2.092
G-1	1328	1.779	1.100	1062	1.423	1.001
G-2	1565	2.097	1.290	1330	1.782	1.187
G-3	1848	2.477	1.365	1331	1.783	1.269
G-5	2180	2.920	2.850	1330	1.781	2.109
G-6	4.465	4110	2780	1.562	1562	2113
F-1	4.000	-	857	3.400	-	754
F-2	5.000	-	1.272	3.400	-	1.170
F-3	6.400	-	1.895	3.904	-	1.800
F-4	7.800	-	1.520	3.900	-	1.186
F-5	10.400	-	1.520	4.992	-	1.186



Load Case 3 and CS = 1,2						
Standard Strength	Load for broken conductor crossarm (daN)			Load for every earth wire (daN)		
	Li	Ti	Vi	Lei	Tei	VeI
L-0	1025	-	250	-	-	220
L-1	1375	-	500	-	-	435
L-2	1620	-	1.212	-	-	1091
L-3	1915	-	1.715	-	-	1.612
M-0	2050	-	600	-	-	528
M-1	2750	-	1.120	-	-	1019
M-2	3240	-	1.290	-	-	1.187
M-3	3975	-	1.855	-	-	1.762
M-4	4515	-	3.735	-	-	2.092
G-1	2654	711	1.100	-	569	1.001
G-2	3127	838	1.290	-	712	1.187
G-3	3696	990	1.365	-	713	1.269
G-5	4361	1.169	2.850	-	713	2.109
G-6	7.020	1880	2780	-	714	2113
F-1	5.000	-	857	-	-	754
F-2	6.000	-	1.272	-	-	1.170
F-3	7.500	-	1.895	-	-	1.800
F-4	9.600	-	1.520	-	-	1.186
F-5	12.000	-	1.520	-	-	1.186

Load Case 4 and CS = 1,2						
Standard Strength	Load for every crossarm (daN)			Load for broken earth wire (daN)		
	Li	Ti	Vi	Lei	Tei	VeI
L-0	-	-	250	2000	-	220
L-1	-	-	502	2135	-	437
L-2	-	-	1.211	2750	-	1090
L-3	-	-	1.718	2750	-	1.615
M-0	-	-	602	2000	-	530
M-1	-	-	1.121	2750	-	1020
M-2	-	-	1.293	2750	-	1.190
M-3	-	-	1.847	2750	-	1.755
M-4	-	-	3.768	2750	-	2.110
G-1	-	1.428	1.099	2132	571	1.000
G-2	-	1.653	1.293	2653	711	1.190
G-3	-	1.975	1.360	2653	711	1.265
G-5	-	2.294	2.851	2653	711	2.110
G-6	-	3742	2776	2.653	711	2110
F-1	-	-	860	3.900	-	757
F-2	-	-	1.273	3.900	-	1.171
F-3	-	-	1.889	3.900	-	1.795
F-4	-	-	1.538	3.900	-	1.200
F-5	-	-	1.538	3.900	-	1.200

Load Case 3 (End of Line Funtion) and CS = 1,2						
Standard Strength	Load for every crossarm (daN)			Load for every earth wire (daN)		
	Li	Ti	Vi	Lei	Tei	VeI
F-1	2.640	1.122	857	2.719	954	754
F-2	3.280	1.341	1.272	2.722	952	1.170
F-3	3.680	1.830	1.895	3.128	1.171	1.800
F-4	4.800	2.055	1.520	3.600	1.027	1.186
F-5	6.640	2.618	1.520	4.847	1.257	1.186

Load Case 4 (End of Line Funtion) and CS = 1,2						
Standard Strength	Load for every crossarm (daN)			Load for every earth wire (daN)		
	Li	Ti	Vi	Lei	Tei	VeI
F-1	2.400	1.600	857	2.328	800	754
F-2	3.000	1.923	1.272	2.340	865	1.170
F-3	3.840	2.378	1.895	2.342	1.094	1.800
F-4	3.900	3.633	1.520	1.950	690	1.186
F-5	5.200	4.825	1.520	2.496	676	1.186

### 5.5.5 Standard Graphs

Every set of load case and security coefficient can be represented on a graph that depicts on X-axis de representative longitudinal load and on Y-axis the representative transversal loads.

On that graph is depicted the line formed by every combination of loads L-T in which the security coefficient is that indicated on the graphic for a given representative vertical load.

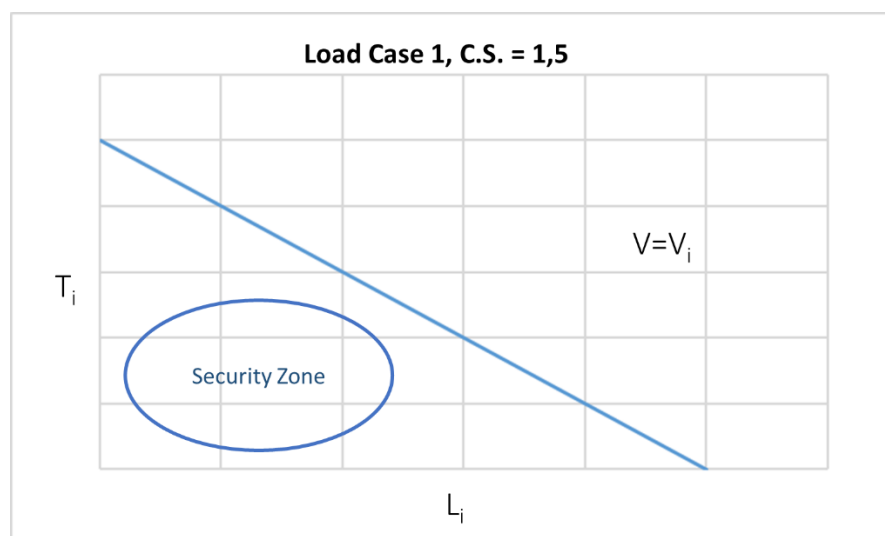

Example of standard graph.



	GLOBAL STANDARD	Page 17 of 94
	LATTICE STEEL SUPPORTS FOR HIGH VOLTAGE LINES	GSCS001 Rev. 01 05/02/2024

The area between the graphs axes and that line represents all the combinations of loads in which security coefficients of the tower is greater than that indicated, and then it is safe to use the support. The values indicated on the tables of paragraph 5.5.4 can be represented as a point in those graphs' lines.

For every load case it is defined a standard graphic where every point represents a combination of load of that case. All standard loads included in that load case, as indicated in paragraph 5.5.1, have to be related uniquely to representatives L and T, in a way that for every point in the graph all loads acting on the tower are known. For that purpose, for every standard graph there are defined coefficients to relate the loads on conductor to loads on earth wire. Those coefficients are  $\alpha$ ,  $\beta$  and  $\lambda$ , where:

$$L_{ea} = L_i \times \alpha$$

$$T_{ea} = T_i \times \beta$$

$$V_{ea} = V_i \times \lambda$$

Due to these graphs is possibly the use of combinations of L and T forces different from that indicated on the tables in paragraph 5.5.4.

For a tower to be assigned a standard strength, it is necessary to fulfil the requirements of security coefficients at any point of the line depicted in the standard graphs.

The standard graphs that match to every standard strength are included in Annex A.

## 5.6 Standard Clearances

### 5.6.1 Distance between phase conductors

The minimum distance between any attachment point of phase conductors and any other attachment point of conductor or earth wires shall be equal or greater than one of the Table 1 below.

Designation of the support will include this value of the table as indicated on paragraph

Distance between conductors (m)								
Designation value								
2,5	3,0	3,5	4,0	5,0	5,5	6,5	7,0	7,5
25	30	35	40	50	55	65	70	75

Table 1

As an example, in Figure nº 1 it is depicted a support where distance between conductors is marked as D, E and F. In case a support it is designed with a distance between conductors of 40, then D, E and F shall be equal or greater than 4 m.

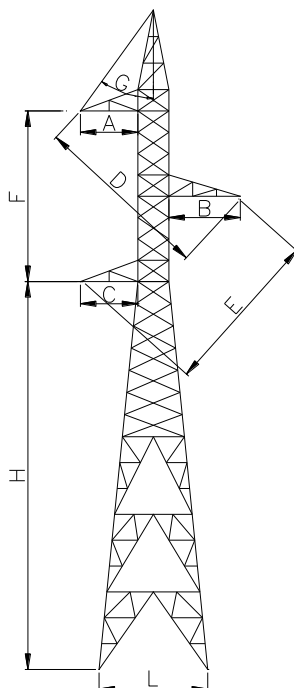

Figure nº 1

### 5.6.2 Distance between phase conductors and earthed parts

The minimum distance between any attachment point of phase conductors and any earthed parts of the support, apart from the cross-arm, shall be equal or greater than one of the indicated on Table 2.

The voltage indicated in the table is just an orientation. Designation of the support will include a value representative of that distance as indicated on paragraph 6.

Tower Type Group	Unified voltage values (kV)	Length of crossarm (m)	Designation Value
A	220	4,00	40
		3,50	35
B	150	2,60	26
	138		
	132	2,30	23
	115		
	110		
C	69	1,50	15
	66		
	45		

**Table 2**

As an example, in Figure n° 1 it is depicted a support where distance between conductors and earthed parts is marked as A, B and C. In case a support it is designed with a distance between conductors as 23, then A, B and C shall be equal or greater than 2,3 m.

### 5.7 Standard Height

The distance from the lower attachment point of phase conductors to the ground plane shall be equal to one of the included in the table below.

Standard height (m)									
10	12	15	18	21	24	27	31	35	39

**Table 3**

As an example, in Figure n° 1 it is depicted a support where standard height is marked as H.

### 5.8 Base Surface

The dimensions of the support at the ground level will not occupy any surface outside a square area of the length indicated at the table below.

Length at base support (m)										
Standard Height	10	12	15	18	21	24	27	31	35	39
One block foundation	2,25	2,34	2,46	2,59	2,71	2,84	2,96	3,13	3,3	3,46
Separate foundations	3,75	4,14	4,71	5,29	5,86	6,44	7,01	7,78	8,55	9,31

**Table 4**

	GLOBAL STANDARD	Page 20 of 94
	LATTICE STEEL SUPPORTS FOR HIGH VOLTAGE LINES	GSCS001 Rev. 01 05/02/2024

### 5.9 Attachment point of conductor and earth wire

Regardless the standard strength or the type of the support, it could always be used with any function of those indicated on paragraph 5.3. with suspension or tension insulation chains, regarding that all strength and dimensional needs of the line are met. For that aim, all the attachment point of conductor must allow the use of both type of insulation chains in a simple way.

At crossarms, the attachment point for conductor will be designed with three holes prepared for horizontal chains and an additional hole prepared for vertical chains.

The axis of the holes prepared for horizontal insulation chains will be perpendicular to the horizontal plane and the holes will be arranged forming a horizontal isosceles triangle with the base parallel to the direction of the line.

The axis of the hole prepared for vertical insulation chains shall be parallel to the direction of the line.

The diameter of these holes will be between 21.5 and 22 mm. unless another dimension is expressly specified.

As an example of this disposition for attachment point of conductor at crossarms is depicted Figure n° 2.

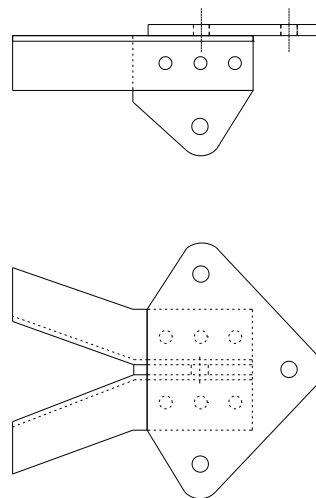
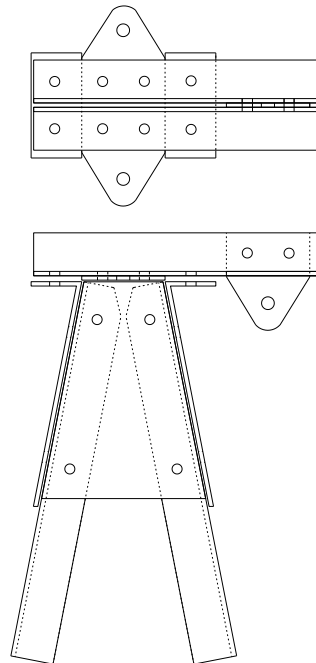

**Figure n° 2: Example of point of attachment at crossarm**

For earth wires it must be fulfilled the same purpose, and it must be allowed the attachment of the earth wire with tension or suspension function in an easy way.

Furthermore, in case of suspension function, the earth wire must be hold outside of the frame of the support, at one side of the support at least 20 cm away from it, or by means of a prefabricated hardware, as a C-block.

Examples of those dispositions for attachment point of earth wire are depicted on Figure n° 3 and Figure n° 4.



**Figure nº 3: Example of point of attachment for earth wire**

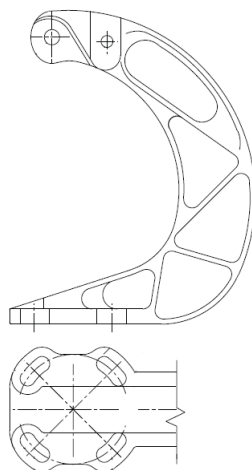

**Figure nº 4: Example of C-block**

At the mean angles of the support, near of the attachment point for the earth wire there must be an auxiliary hole for earthing purposes.

	GLOBAL STANDARD	Page 22 of 94
	LATTICE STEEL SUPPORTS FOR HIGH VOLTAGE LINES	GSCS001 Rev. 01 05/02/2024

### 5.10 Maintenance Facilities

Every part of the tower must be accessible for inspection and cleaning.

Lattice steel towers shall be provided with walkways for climbing and access equipped with technical devices for protection from falling such as rope protection systems, section rail systems, safety step bolts (e. g. pig tails) etc.

These walkways may consist of:

- Ladders;
- Step bolt arrangements;
- Stirrup arrangements.

If walkways are arranged at the leg members, they shall be provided at two opposite leg members.

Alternatively, the walkways with technical devices for protection from falling may be designed with one of the following:

- a single step bolt arrangement or a step ladder at tower faces perpendicularly to the line direction
- a ladder within the tower body

To provide protection against unauthorized climbing, these walkways should start around 2 m above ground level.

Step of any kind shall be rated for a foot tread load of 200 daN acting vertically at a structurally unfavorable position.

Unless otherwise specified, it is not necessary to provide any protection of the framework against unauthorized climbing.

## 6 DENOMINATION OF SUPPORTS

The denomination of one support will identify it with respect to the minimum efforts that it supports on every load case and its characteristic dimensions, and will consist of:

- A letter showing the number of circuits:
  - S: one circuit (tree crossarms)
  - D: two circuit (six crossarms)
  
- A letter followed by a slash and a number showing the standard strength indicated on paragraph 5.5.4 and 5.5.5:

Standard strength of supports			
Type L	Type M	Type G	Type F
L-0	M-0	G-1	F-1
L-1	M-1	G-2	F-2
L-2	M-2	G-3	F-3
L-3	M-3	G-5	F-4
	M-4	G-6	F-5

**Table 5**

According to the position and the function in the line, towers usually are selected as follows:

- Supports type L are used as alignment support with suspension function.
- Supports type M are used as alignment support with tension or anchorage function.
- Supports type G are used as angle support with anchorage function.
- Supports type F are used as alignment support with terminal function.

Nevertheless, any type of supports can be used as alignment or angle support with any function as long as the loads that need to resist are equals or lowers than those indicated for the standard strength in the relevant load cases.

- A three-letter code to show the disposition of the support as indicated in paragraph 5.2 and the table below:
  - : Tresbolillo.
  - : Doble bandera.
  - TRI: Triangle
  - CAP: Capa
  - HEX: Hexagon.
  - DAN: Danubio.
  - BAN: Bandera.
  - POR: Portico.
  - GAT: Cara de gato.
  
- The code MON, in case the foundations of the support are monolithic type, and then the base surface occupied by the support is that indicated in paragraph 5.8 for one block foundations
  
- A two-digit number followed by a hyphen indicating the separation distance between conductors in decimeters as indicated on paragraph 5.6.1.
  - 25: for a minimum distance between conductors of 2,50 m.
  - 30: for a minimum distance between conductors of 3 m.

	GLOBAL STANDARD	Page 24 of 94
	LATTICE STEEL SUPPORTS FOR HIGH VOLTAGE LINES	GSCS001 Rev. 01 05/02/2024

- 35: for a minimum distance between conductors of 3,5 m.
  - ...
  - 75: for a minimum distance between conductors of 7,50 m.
- A two-digit number followed indicating the clearance distance from conductors in decimeters as indicated on paragraph 5.6.2.
    - 15: for a minimum cross-arm length of 1,50 m.
    - 20: for a minimum cross-arm length of 2,00 m.
    - 23: for a minimum cross-arm length of 2,30 m.
    - 26: for a minimum cross-arm length of 2,60 m.
    - 35: for a minimum cross-arm length of 3,50 m.
    - 40: for a minimum cross-arm length of 4,00 m.
  - A two-digit number followed by the letter m to indicate the useful height of the support according to section 5.7:
    - 10 m.: for a standard height of 10 m.
    - ...
    - 39 m: for a standard height of 39 m.

The designation of the standardized support, an identification of the manufacturer and the year of manufacture must be engraved on the bottom of the uprights, approximately 1.5 m. over the ground level and visibly in an easy way.

## 6.1 Examples of denomination

**DM-1 30-15 15m:** Indicates a support for double circuit type M-1 with 3 m. of distance between conductors, crossarms of at least 1.5 m. in length, and a useful height of 15 m.

**SG-3 MON 40-23 21m:** Indicates a support for simple circuit, type G-3 with 4 m. of distance between conductors, crossarms of at least 2.3 m. in length, and a useful height of 21 m. The foundation is made of one block with a side smaller than 2,71 m.

**SM-2 TRI MON 50-26 27m:** Indicates a support for simple circuit with disposition of conductor type triangle, strength type M-2 with 5 m. of minimum distance between conductors, crossarms of at least 2.6 m. in length and a useful height of 27 m. The foundation is made of one block with a side smaller than 2,96 m.



## 6.2 Example of designation of support

For a designer of a line, it is needed to choose a support that carries one circuit and an earth wire with a disposition type triangle. For a load case including wind of  $V_{b,0} = 26$  m/s the forces on the point of attachment due to conductor or earth wire (including wind forces on conductors) are:

- Longitudinal Load on every conductor,  $L_i = 192$  daN
- Transversal Load on every conductor,  $T_i = 854$  daN
- Vertical Load on every conductor,  $V_i = 342$  daN
- Longitudinal Load on earth wire,  $L_{ea} = 101$  daN
- Transversal Load on earth wire,  $T_{ea} = 450$  daN
- Vertical Load on earth wire,  $V_{ea} = 132$  daN

Those forces need to be resisted by the chosen tower with a security coefficient equal or greater than 1,5

The distance required between phases on the tower is 3,38 m

The length required for the crossarm, from the point of attachment of conductors to the tower body is 2,12 m

The height required from the point of attachment of the lower conductor to ground is 21 m.

It is required a compact foundation in one block.

The standard tower that fulfill all those requirements is the following:

- As a single circuit denomination will start with a letter **S**
- Strength is decided from graphic of Load Case 1 with  $CS=1,5$

Representing the point of the tower on the graphic it is needed to choose one type that is over it. In this case is type **M-1**.

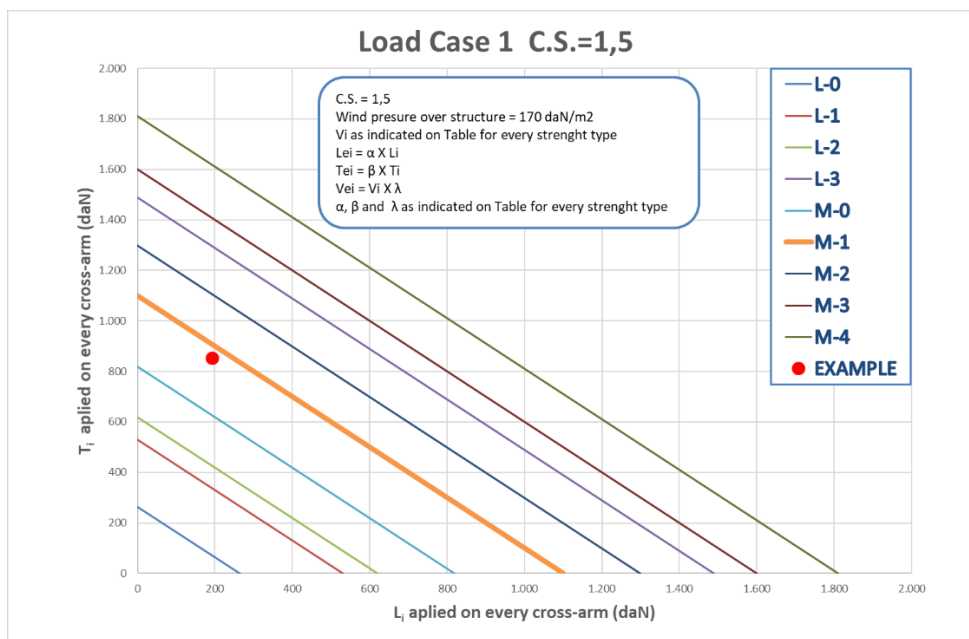

Once chosen type M-1, it has to be checked that vertical load of conductors and loads on earth wire are lower than those of the graphic.

For a type M-1, the range of vertical loads supported by every conductor within the security coefficients allowed is 0 to 1.120 daN, The example load  $V_i = 342$  daN is included, so it is valid.

The loads of earth wires in a graphic are related to loads on conductors by the following coefficients:

Case Load 1	$\alpha$	$\beta$	$\lambda$
M-1	0,68	0,68	0,63

So, load resisted on earth wire by a type M-1 in the point of work of the example are:

$$L_{ea} = L_i \times \alpha = 192 \times 0.68 = 131 \text{ daN}$$

$$T_{ea} = T_i \times \beta = 854 \times 0.68 = 581 \text{ daN}$$

$$V_{ea} = V_i \times \lambda = 342 \times 0.63 = 216 \text{ daN}$$

And comparing with the load required it is concluded that Type M-1 resist the loads required on conductors and earth wire with a security coefficient greater than 1.5.

	Load for M-1	Load required	Check
$L_i$	192	192	OK
$T_i$	854	854	OK
$V_i$	0 to 1.120	342	OK
$L_{ea}$	131	101	OK
$T_{ea}$	581	450	OK
$V_{ea}$	216	132	OK

- It is required disposition Triangle, then denomination continue with **TRI**
- It is required one block foundation, then denomination continue with **MON**
- It is required a minimum distance between conductors of 3.38, so it is used the immediate superior standard distance defined on paragraph 5.6.1, that is 4 m and indicated in denomination as **40**
- It is required a minimum length of crossarms of 2.12, so it is used the immediate superior standard distance defined on paragraph 5.6.25.6.1, that is 2,3 m and indicated in denomination as **23**
- It is required a height of 21 m, then denomination finish with **21m**

Eventually the standard denomination of the tower that fulfill all those requirements is the following:

**SM-1 TRI MON 40-23 21m**

	GLOBAL STANDARD	Page 27 of 94
	LATTICE STEEL SUPPORTS FOR HIGH VOLTAGE LINES	GSCS001 Rev. 01 05/02/2024

## 7 CONSTRUCTION CHARACTERISTICS

### 7.1 General Characteristics

#### 7.2 Materials

Angles and plaques:

In general, only the structural steel grades S235, S275 as well as S355J0 and S355J2 according to EN 10025-1:2005 02 and EN 10025 2:2005 04 may be used.

It is also possible the use of equal-sided angle profiles and high-strength, normal steel plates in accordance with ASTM A-36 for normal steel, and ASTM A572 grade 50 for high-strength steel.

Nevertheless, it is not possible the use of steel according to EN standards and ASTM standards simultaneously on the same tower.

The minimum thickness allowed for profiles will be 6 mm for the uprights and cross members elements, and 4 mm for the other elements.

The thickness of joint plates will be equal or greater than those of the profiles that are jointed, with a minimum of 6 mm.

If weakened by boreholes, angle sections with a width below 40 mm are inadmissible. In case there is admitted the use of welded angles, the minimum width for those angles will be 35 mm.

Profiles less than 60mm x 60mm x 6mm will not be used for studs and cross members.

Bolts:

According to ASTM A394 or EN-ISO 898-1

In general, only the strength qualities 5.6 and 8.8 shall be used.

The minimum bolt diameter will be 16 mm for the uprights and 12 mm for the other elements.

#### 7.3 Welding

Welding operations shall be in accordance with EN 1090-1.

Special care shall be taken to ensure proper galvanizing.

Welded angles shall only be used with previous consent of Enel for the specified tower.

In any case, welding on site it is not allowed.

#### 7.4 Connections

The connections between profiles will be designed in such a way that their axes are at the same point, minimizing the eccentricities.

The joints between the elements of the tower structure will be made usually by bolts and nuts, also using joint plates or connection profiles where necessary.

	GLOBAL STANDARD	Page 28 of 94
	LATTICE STEEL SUPPORTS FOR HIGH VOLTAGE LINES	GSCS001 Rev. 01 05/02/2024

Bolted connections shall be secured against loosening. This can be achieved by an adequate tightening of the nuts, or using nut and jam nut. Spring washers may be used as an indication for enough tightening.

It is not allowed the use of punching methods for holes on angles or plates with thickness greater than 10 mm. Nevertheless, drills can be punched to a diameter smaller than the final diameter.

Structural members of crossarms permanently loaded in tension shall not be punched.

Any kind of perforation by drilling or punching on site it is not allowed.

Strength calculation and geometry design of connections will follow the recommended rules indicated on EN 1933-1-8 "Eurocode 3: Design of steel structures - Part 1-8: Design of joints" or ASCE 10-15 "Design of Latticed Steel Transmission Structures" with special attention to edge and borehole distances. In any other case, connections resistance will be checked by test or justified by specific calculations.

### 7.5 Anchor Stub

Unless otherwise specified, stubs are to be supplied for their use in concrete foundations.

The stubs will come with holes to install the cleats at the assembly stage. The stub provision includes cleats and their bolts.

The two transversal dimensions of the stub will always be equal or greater than the connection amount.

For grounding, holes will be made 60 cm below ground level.

At least four (4) holes will be supplied for javelin installation per tower.

### 7.6 Corrosion protection

All metal parts, bolts, nuts and washers will be hot dip galvanized according to the recommendations indicated in ISO 1461:2010 or ASTM A123.

The galvanizing must be uniform, free of lumps and bubbles, with good adhesion, so as to allow proper assembly of the different components.

The thickness of the zinc coating shall not be less than 78  $\mu\text{m}$  on any point, with a mean value greater than 86  $\mu\text{m}$  on every element. The mass of the zinc coating shall not be less than 610 g /  $\text{m}^2$ .

When specifically asked, a coat of anticorrosive paint will be applied to all the elements of the tower before dispatching them from the workshops. It will be of such a structure that mechanically and chemically protects the galvanized coating and that it does not come off easily.

## 8 TESTING

### 8.1 Factory acceptance tests

For the inspection, the material corresponding to the order or batch will be stored by type of support and number in a specific and easily accessible area.

	GLOBAL STANDARD	Page 29 of 94
	LATTICE STEEL SUPPORTS FOR HIGH VOLTAGE LINES	GSCS001 Rev. 01 05/02/2024

It will be checked that all the material has been properly packed and protected to prevent damage and loss during transport, that every package has been correctly labeled and that all packages included in the order or batch have been presented to inspection.

From all those packages there will be selected a group to be tested, formed by all the packages from 5 %, rounded up, of the towers forming the batch.

The acceptance test for that group of packages are the following.

#### 8.1.1 Visual inspection

Verification that the content of all the packages of bars and joint plates and 10% of the packages of bolts correspond to that listed on the packing list. Checking that the individual components are complete with the markings provided and that those markings are clearly legible. Specifically, it will be verified that the standard denomination of the support and the year of manufacture are visibly engraved on the lower part of the uprights, and that this mark appears on the drawings of the support.

Furthermore, it should be checked that there are no defects of processing, that the materials do not have lamination defects, and they are free from local, flexural and torsional deformations and that the holes do not present tapering due to the use of worn punches.

#### 8.1.2 Dimensional verification

A dimensional check of 2% of angles, 2% of joint plates and 2% of bolts used for visual inspection will be carried out. That pieces will be selected, if possible, ensuring that the pieces are different from each other.

It must be checked that all dimensions correspond to those shown in the construction drawings

The tolerances for those measurements are as follows:

- |   |           |
|---|-----------|
| ○ total dimension of the piece:                       | 1 mm / m  |
| ○ hole centers from different groups:                 | 1 mm / m  |
| ○ hole centers from the same group:                   | 1 mm      |
| ○ profiles gravity center:                            | 1 mm      |
| ○ displacement of one face with respect to the other: | 1 mm      |
| ○ hole's diameters:                                   | -0; + 3mm |
| ○ straightening of main bars:                         | 2/1000    |
| ○ straightening of lattices and secondary bars:       | 1/1000    |

#### 8.1.3 Galvanization verification

On every sample used for dimensional verification, it will be verified the quality and the thickness of the galvanizing using the magnetic method.

	GLOBAL STANDARD	Page 30 of 94
	LATTICE STEEL SUPPORTS FOR HIGH VOLTAGE LINES	GSCS001 Rev. 01 05/02/2024

#### 8.1.4 Inspection of welds

On every sample used for dimensional verification, welds will also be visually inspected. Inspector has the possibility to ask for scrape and inspection by penetrating liquids of the pieces that are considered appropriate.

#### 8.1.5 Material properties verification

It must be checked that the materials used correspond to those prescribed in construction drawings. For this purpose, there must be provided the certificates of origin of the materials used. Then, tensile and resilience tests will have to be carried out on samples from two angles and two plates. And tensile test on samples from two bolts.

#### 8.1.6 Weight verification

Verification that the total weight of every package selected for acceptance tests is greater than 98% of the theoretical weight indicated in the support reference documentation.

For every test, in case of failure on more than one sample the batch must be rejected.

In case of failure on one sample, there will be selected a new group of samples to be tested doubled than the initial one, if any of these new samples fail, the batch must be rejected.

## 8.2 Type test

Towers design must be validated by mean of tests to check their strength.

Tests shall be performed on a full-sized prototype of the structure and/or components of the structure.

Reference standard for those tests is EN 60652:2004 "Loading test on overhead line structures" or Chapter 6 from ASCE 10-95 "Design of latticed steel transmission structures".

The prototype to be tested must have successfully passed all the factory acceptance tests indicated on paragraph 8.1, except for 8.1.3.

A test is completed successfully when 100% of nominal loads are applied for a time longer than a minute without failure and there are not local plastic deformations such as bowing or warping on any element.

Enel could choose to accept a tower design not validated by a full-sized prototype test, as long as it have the stress coefficients of all the elements as a function of their own weight, wind on the structure and unit loads applied in three dimensions at all the connection points of the conductor and ground cable or all the information necessary to be able to obtain these coefficients by means of commonly used calculation programs. This information includes, among others, the following data:

- Complete description of the support and foundation geometry.
- Geometry of the lines of axes of the bars or "wire model", and scheme.
- Complete description of each of the profiles used, including:

	GLOBAL STANDARD	Page 31 of 94
	LATTICE STEEL SUPPORTS FOR HIGH VOLTAGE LINES	GSCS001 Rev. 01 05/02/2024

- Catalog and section
- Type of steel
- Length
- Complete description of all joints including the number, diameter and location of the bolts and holes used as well as characteristics of the gussets, linings or welds used.

In addition, in these cases, a first support or prototype will be assembled with all its parts that will be visually inspected in search of possible defects, checking that all the parts assemble perfectly without the need to use a reamer and a photographic report of the assembly of the prototype will be issued.

## 9 SUPPLY REQUIREMENTS

The material supply of the different elements must consider a series of attentions intended to eliminate any type of error in the identification and ultimately facilitate the assembly and erection of the tower.

Thus, on the one hand, the identification of elements and modes of assembly must be unambiguous so that they can always be verified, before and after assembly. In particular, the following specifications should be considered:

- The identification of the supports, especially in the uprights and at least one of them in a stamped shape, will consist of: the supplier's logo, the denomination of the support according to this standard and the year of manufacture
- All loose elements must be indelibly marked and identified for assembly with a number and support to which it is intended.
- The bolts will be engraved with the manufacturer's mark and quality.

### 9.1 Packing

Regarding the shipping method and its preparation for assembly, the following indications should be considered:

- The components of a support must be packed with straps and forming a minimum number of packages, manageable in transport and on site.
- These packages will be identified with a label to embrace it by the strap and identified with the following elements:
  - Specific identification in reference to the line and project.
  - Identification of the support on the line (support number).
  - Provider
  - Type of support, nominal tension, height and distance between conductors.
  - Destination address
  - Name of the package (upper cross, 1<sup>st</sup> section, etc.)

	GLOBAL STANDARD	Page 32 of 94
	LATTICE STEEL SUPPORTS FOR HIGH VOLTAGE LINES	GSCS001 Rev. 01 05/02/2024

- Package number and total number of packages (as an example: 1/5, 2/5, etc.)
- Each package will be accompanied by its list of materials.
- With every support, its assembly drawing will be supplied.
- Loose elements such as bolts, nuts, washers, bushings, plates, etc., must be supplied in suitable boxes, with the identification indicated above. Bolts will be supplied grouped by measure, identifying each of the different groups.

## 10 DOCUMENTATION

The following list indicates the minimum technical information that suppliers shall provide for every tower.

- Layout drawings with indication of profiles, bolts, principal dimensions and total weight of the tower.
- Detailed drawings for erection.
- Bill of material with indication of elements marks, weights, section profiles and materials.
- Packing list, including bolts with indication of lengths.
- Information and drawings for foundations.
- Standard graphs, or equivalent, showing real strength of the tower and utilization limits.
- Representation BIM for each tower.



	GLOBAL STANDARD	Page 33 of 94
	LATTICE STEEL SUPPORTS FOR HIGH VOLTAGE LINES	GSCS001 Rev. 01 05/02/2024

**LOCAL SECTION A – Enel Distribución Colombia**

	GLOBAL STANDARD	Page 34 of 94
	LATTICE STEEL SUPPORTS FOR HIGH VOLTAGE LINES	GSCS001 Rev. 01 05/02/2024

## LOCAL SECTION B – Enel distribución Perú

### B1. Design, Normal Height and Leg Extension

The manufacturer must consider a body extension +6 and the maximum leg of +2 for the design of the structures (Most critical combination)

The normal height from the level of the crosshead below ground level is  $h \pm 0$  is 15 m for a suspension tower and 13 m for angle towers.

The lower part of each type of tower must be designed in such a way that its height can be easily varied by fixed sections of 3 m, up to maximum variations of minus three (-3) to plus six (+ 6) meters with respect to the normal height, without the need to modify the upper part of the tower.

Furthermore, to adapt to the asymmetric profile of the terrain, the height of each leg of any type of tower and extension must be easily varied, independently of the others, by fixed sections of one (1) meter, from minus one (-2) meter plus three (+ 3) meters.

### B2. Standards

In addition to the standards indicated in 3.2, consider the following:

ASTM A36	Perfiles y placas de acero estructural.
ASTM A572-Grado 50	Perfiles y placas de acero de alta resistencia.
ASTM A6	Requerimientos para el suministro de perfiles y placas de acero.
ASTM A394	Pernos y tuercas galvanizados.
ANSI B18.21.1	Arandelas de presión.
ANSI B18.2.1	Pernos hexagonales y roscas.
ANSI B18.2.2	Tuercas hexagonales.
ASTM A123	Galvanización de perfiles.
ASTM A153	Galvanización de ferreterías, pernos, tuercas y arandelas.
ASTM B201	Cromatización de piezas galvanizadas.
ASCE No. 52	Guide for Design of Steel Transmission Towers.
IEC 60652	Loading Test on Overhead Line Structures.
CNE	Código Nacional de Electricidad (Suministro 2011)

### B3. DISEGN CRITERIA AND CALCULATION

#### B3.1 Distance between phase conductors and earthed parts

220kV:

- **Minimum** vertical distance between conductors: 6,5 m
- **Minimum** distance between conductors and earthed parts: 2,50 m

	GLOBAL STANDARD	Page 35 of 94
	LATTICE STEEL SUPPORTS FOR HIGH VOLTAGE LINES	GSCS001 Rev. 01 05/02/2024

60kV:

- **Minimum** vertical distance between conductors: 3,5 m
- **Minimum** distance between conductors and earthed parts: 1,00 m

### *B3.2 Load cases*

In addition to what is indicated in 5.5.2, the following criteria must be considered for the design and calculation of the elements of the tower structure:

#### **Service load**

Under conditions of service loads, it will be admitted that the tower is subject to the simultaneous action of the following:

- **Vertical loads**  
The weight of conductors, insulators, accessories, guard wire, tower and a man's weight.
- **Horizontal loads**
  - Wind pressure, over the total projected area.

The wind load on the tower structure will be verified as indicated in the CNE code

$$W = 3,2 \cdot q \cdot A$$

Where:

W = Is the total wind load (daN)  
q = Is the wind pressure, (daN/m<sup>2</sup>)  
A = Is the total surface exposed to the wind (m<sup>2</sup>)

- The horizontal component of the maximum conductor and guard wire load determined relative to the maximum deflection angle.

- **Longitudinal loads**

	GLOBAL STANDARD	Page 36 of 94
	LATTICE STEEL SUPPORTS FOR HIGH VOLTAGE LINES	GSCS001 Rev. 01 05/02/2024

The longitudinal horizontal component of the maximum working load of the conductor and the guard wire.

- **Assembly and Maintenance Loads**

The additional loads that affect the tower during assembly and maintenance tasks due to personnel and maneuvering equipment.

**Loads of break of one conductor and break of earth wire**

Load condition where the tower is subject, in addition to normal loads to a horizontal force, corresponding to the breakage of a conductor.

This load will have the following value:

- For terminal towers: 100% of the maximum conductor load.
- For terminal towers: 100% of the maximum earth wire load.

This load will be determined in its longitudinal and transverse components, according to the corresponding deviation angle.

The own weight and the wind loads corresponding to the broken conductor will be considered as acting in the middle of the corresponding span.

*B3.3 Calculation Criteria*

**Overload factors**

The grade C overload factor, indicated in the CNE code (Table 253-1), the relationship between the stress of each element of the tower structure and the maximum stress on the same element calculated by the most unfavorable load condition

**Under normal conditions:**

Transverse wind loads	2,2
Transverse tension loads	1,3
Vertical loads	1,5
Longitudinal loads	1,3

When a tower is subjected to a load corresponding to any of the indicated conditions multiplied by the corresponding overload factor, no permanent deformation or failure shall occur.

**Limit Efforts**

	GLOBAL STANDARD	Page 37 of 94
	LATTICE STEEL SUPPORTS FOR HIGH VOLTAGE LINES	GSCS001 Rev. 01 05/02/2024

The limit stress of each element of the tower structure will be:

- For tensile stresses: The elastic limit of steel.
- For compression stresses: The buckling limit stress.

### Buckling Calculation Method

The buckling limit stress is obtained by the following formula:

$$S = \frac{F}{k}$$

Where:

- S = It is the buckling limit stress (daN/mm<sup>2</sup>.)
- F = It is the elastic limit of steel (daN/mm<sup>2</sup>.)
- k = Buckling number determined according to the slenderness ratio of each element and calculated according to a method presented by the Contractor and approved by the Supervisor.

Slenderness ratio ( $\Gamma$ )

The slenderness ratio ( $\Gamma$ ) of a compression element is the ratio between its equivalent buckling length (L) and its minimum turning radius (R).

L : In general, the equivalent buckling length to be considered is the distance between the effectively subject points located in the considered buckling plane. However, when the element is not only subject, but its rotation is impeded at both ends, the effective length to be considered can be 8/10 of the length between the subject points.

R : In general, the turning radius to be considered is the minimum radius of the section. However, when it is certain that there will be buckling in a plane parallel to that of a profile, the turning radius corresponding to such a plane can be considered.

In the case of an element in cross compression and joined to another element in tension, the point of union can be considered as a fixed point in a direction perpendicular to the plane determined by the two elements, provided that the stresses in both elements are approximately equal in magnitude and the union at the point is adequate.

The slenderness ratio of elements to compression shall not exceed the following limits:

- For studs and crosspieces : 150
- For braces, diagonals and other elements : 200
- For redundant elements : 250

### Calculation method

	GLOBAL STANDARD	Page 38 of 94
	LATTICE STEEL SUPPORTS FOR HIGH VOLTAGE LINES	GSCS001 Rev. 01 05/02/2024

The calculation method to be followed will be the latest edition of the Transmission Tower Design Guide for the ASCE - American Society of Civil Engineers.

### Overlapping Loads

The effect of earthquakes on structures should consider the following accelerations:

- Vertical : 0,3 g
- Horizontal : 0,5 g

The resulting horizontal and vertical forces should be applied before considering the overload factor for exceptional loads (F.S = 1.3.) And in windless conditions.

### Particular Design Criteria

In the design of the tower structures, efforts will be made to minimize the number of elements, as well as variety.

The connections between profiles will be designed in such a way that their axes are at the same point, minimizing the eccentricities.

The joints between the elements of the tower structure will be made by bolts and nuts necessary, also using joint plates where necessary. Welds between profiles will not be accepted. All elements of the towers must be assembled with two minimum bolts. The towers will be designed so that all parts are accessible for inspection and cleaning. Pockets or depressions that could store water should have drainage holes.

In the design of the tower, it should be considered that the assembly of the profiles should be downstream and the lateral profiles towards the interior of the tower.

The joints must be able to develop the maximum efforts of the members.

By using connection profiles, the angular edge of the inner profile will be rounded so that it does not interfere with the curvature of the profiles of the structure.

It should be considered that the fixing of the bolts will be with nut and jam nut.

### Loads Tree

The values considered for the load tree are shown below:

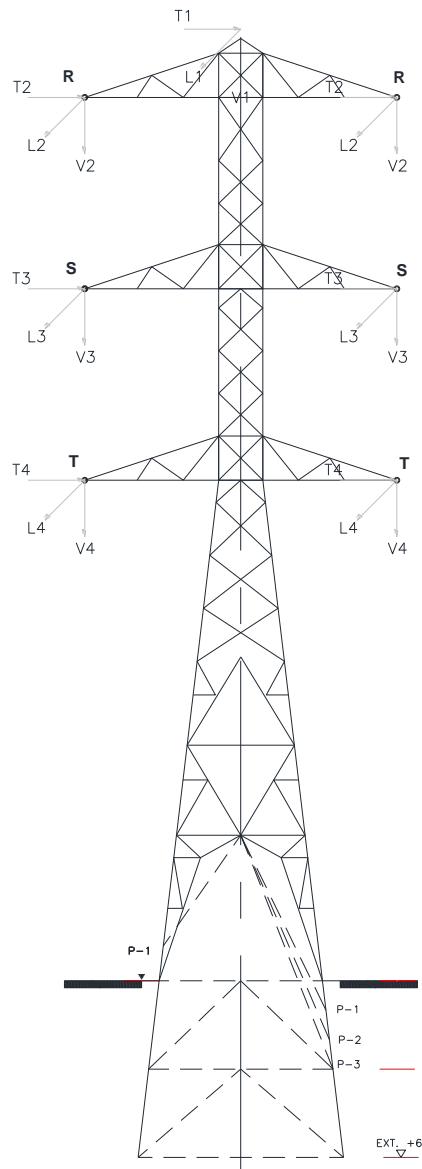

### *Anchor Stub*

The stubs to be supplied will be used in reinforced concrete foundations, for whose design and calculation the maximum loads transmitted by the tower at ground level and concrete of  $175 \text{ kg / cm}^2$  will be used. The load values will be those that result from the structural calculation program of the tower. The stubs will come with holes to install the cleats at the assembly stage. The stub provision includes cleats and their bolts.

The two transversal dimensions of the stub will always be greater than the connection amount. The minimum length is 3.5m.

For grounding, holes will be made 60 cm below ground level.

At least four (4) holes will be supplied for javelin installation per tower.

	GLOBAL STANDARD	Page 40 of 94
	LATTICE STEEL SUPPORTS FOR HIGH VOLTAGE LINES	GSCS001 Rev. 01 05/02/2024

### Maximum deflection

The maximum allowable deflection will be 1.5% of the tower free height, when 100% of the work loads are applied without overload factors.

## B4. CONSTRUCTIVE PRESCRIPTIONS

### Material

Equal-sided angle profiles and high-strength, normal steel plates shall be used for tower structures, in accordance with ASTM A-36 for normal steel, and ASTM A572 grade 50 for high-strength steel or its The standard DIN 17100 or its equivalents is defective, with the following minimum characteristics:

Characteristics	Normal Steel	High Strength Steel
	A 36	A572
Breaking effort (daN/mm <sup>2</sup> )	37-45	52-62
Elastic limit (daN/mm <sup>2</sup> )	25	36
Elongation at break ( $L_0 = 5d_0$ )	25%	22%

### Minimum Sizes

The minimum thickness allowed for profiles and plates will be 6 mm for the uprights and cross members elements, and 4 mm for the other elements.

Profiles less than 60mm x 60mm x 6mm will not be used for studs and cross members, and 35mm x 35mm x 4mm for all other members. The minimum bolt diameter will be 16 mm (5/8") for the uprights and 12 mm (1/2") for the other elements.

The minimum distances and plates to the drilled or punched holes will be the following:

DIAMETER OF CAP SCREW mm (pulgada)	Minimum distance mm (pulgada)	
	FOR CUTTING EDGES	FOR FLYED OR GAS CUTTING EDGES
12 (1/2")	20 (7/8")	16 (3/4")
14 (9/16")	35 (1 1/8")	20 (7/8")
16 (5/8")	70 (1 1/4")	25 (1")
20 (3/4")	80 (1 1/2")	35 (1 1/8")



	GLOBAL STANDARD	Page 41 of 94
	LATTICE STEEL SUPPORTS FOR HIGH VOLTAGE LINES	GSCS001 Rev. 01 05/02/2024

25 ( 1" )	100 (13/4")	70 (11/4")
-----------	-------------	------------

All distances in this column may be reduced by 1/8 "when the hole is at a point where the stress does not exceed 25% of the maximum allowable stress of the element.

The minimum distance between the hole centers should not be less than 2 2/3 times the nominal diameter of the bolt, but preferably not less than 3 diameters.

#### *Cut*

During manufacturing, the profiles, the reinforcement plates and covers them together, etc. they will be cut with a guide and they can be cut or sawn and all metal burrs will be carefully removed. All profiles, reinforcements and joint covers, etc. they will be perfectly straight.

#### *Bent*

Profiles and reinforcing plates that need to be bent will be hot bent. Where for particular reasons the elements are cold bent, the material will be subsequently collected or relieved of tensions.

#### *Perforations*

The structural elements will have all of their perforations made in the shop, so no drilling is required on site to add any extension elements to the towers.

The distance from the center of the bolt holes to the edge of each steel section shall not be less than 1.5 times the bolt diameter.

In addition, the minimum distance between the centers of the holes for adjacent bolts shall not be less than 2.5 times the diameter of the corresponding bolt.

Drills can be punched to a diameter three millimeters smaller than the final diameter or drilled to a diameter one millimeter smaller than the final diameter, if the quality of the steel and the experience of the manufacturer to punch and strip and galvanize are such that they do not verify no danger of breakage.

The final appearance of the perforations should be circular, without burrs or cracks.

#### *Tolerances*

The maximum admissible tolerance in the cut of the pieces will be 1 per thousand.

The maximum allowable difference between the diameter of the hole and the diameter of the bolt shall not exceed 1 mm.

The maximum permissible tolerances in the mutual position of the holes will be as follows:

- At the same end of the profile : ± 0,5 mm.
- Between opposite ends of the profile : ± 1 mm.

	GLOBAL STANDARD	Page 42 of 94
	LATTICE STEEL SUPPORTS FOR HIGH VOLTAGE LINES	GSCS001 Rev. 01 05/02/2024

No tolerance will be allowed in the position of the axis of the perforations with respect to the axis of the profile.

#### *Joints*

The upright joints will preferably be of the stop type, however, overlay joints may be used with prior approval.

The corners of the profiles will be opportunely chamfered in order to ensure direct and continuous contact between the walls of the profiles. The minimum length of the joints will be at least 300 mm with a minimum of 6 bolts.

#### *Marked*

All elements of the structures for the different types of towers will be marked.

#### *Pieces to be embedded*

Parts intended to be embedded in foundation concrete will have adequate devices to increase adhesion between steel and concrete.

#### *Galvanization*

All metal parts, bolts, nuts and washers will be galvanized according to the recommendations indicated in ASTM A123, A 153 and A394.

The galvanizing must be uniform, free of lumps and bubbles, with good adhesion, so as to allow proper assembly of the different components.

The thickness of the zinc coating shall not be less than 600 g / m<sup>2</sup> for the elements of the exposed metal structure and not less than 800 g / m<sup>2</sup> for the buried elements.

To all the elements of the tower, a coat of anticorrosive paint will be applied before dispatching them from the workshops. It will be of such a structure that it mechanically and chemically protects the galvanizing and that it does not come off very easily.

	GLOBAL STANDARD	Page 43 of 94
	LATTICE STEEL SUPPORTS FOR HIGH VOLTAGE LINES	GSCS001 Rev. 01 05/02/2024

**LOCAL SECTION C – Enel distribución Chile**

	GLOBAL STANDARD	Page 44 of 94
	LATTICE STEEL SUPPORTS FOR HIGH VOLTAGE LINES	GSCS001 Rev. 01 05/02/2024

## LOCAL SECTION D – Enel Distribuição Rio, Ceará and São Paulo

### 3.3 Local Standards

- NBR5422- PROJETO DE LINHAS .AÉREAS DE TRANSMISSÃO DE ENERGIA ELÉTRICA
- NBR5426 - Planos de amostragem e procedimentos na inspeção por atributos.
- NBR5909 - Cordoalhas de fios de aço zincados para estais, tirantes, cabos mensageiros e uso similares.
- NBR6153 - Produto metálico - Ensaio de dobramento semi-guiado.
- NBR6323 - Galvanização de produtos de aço ou ferro fundido - especificação.
- NBR7397 - Produto de aço ou ferro fundido revestido por zinco por imersão a quente - determinação da massa do revestimento por unidade de área - método de ensaio.
- NBR7398 - Produto de aço ou ferro fundido galvanizado por imersão a quente – verificação da aderência do revestimento - método de ensaio.
- NBR7399 - Produto de aço ou ferro fundido galvanizado por imersão a quente – verificação da espessura do revestimento por processo não destrutivo – método de ensaio.
- NBR7400 - Galvanização de produtos de aço ou ferro fundido por imersão a quente – verificação da uniformidade do revestimento - método de ensaio.
- NBR8842 - Suportes metálicos treliçados para linhas de transmissão – resistência ao carregamento.
- NBR8851 - Parafuso sextavado para uso estrutural – dimensões.
- NBR8852 - Porca sextavada - acabamento grosso - características e dimensões - padronização.
- NBR8853 - Porta sextavada de segurança para estruturas metálicas de linhas de transmissão e subestações.
- NBR8855 - Propriedades mecânicas de elementos de fixação – parafusos e prisioneiros – fixação.
- ASTM A36/A36M - Standard specification for carbon structural steel.
- ASTM A143 - Standard practice for safeguarding against embrittlement of hot-dip galvanized structural steel products and procedure for detecting embrittlement.
- ASTM A275 - Standard practice for magnetic particle examination of steel forgings.
- ASTM A370 - Standard test methods and definitions for mechanical testing of steel products.
- ASTM A668/A668M - Standard specification for steel forgings, carbon and alloy, for general industrial use.
- ASTM A711/A711M - Standard specification for steel forgings stock.

	GLOBAL STANDARD	Page 45 of 94
	LATTICE STEEL SUPPORTS FOR HIGH VOLTAGE LINES	GSCS001 Rev. 01 05/02/2024

## APPLICATION DEFINITION

The configuration of the towers obtained in this project is preferably applicable to transmission installations in the voltage class of 138 kV, double circuit, intended for passing lanes with a minimum width of 16.00 meters. However, in special situations, they can be applied to transmission lines at electrical voltages of 69 kV, in the case of the States of Ceará and Rio de Janeiro, and 88 kV, in the case of the São Paulo concession area, provided that prior analysis of the mechanical requests acting on the towers in the design of transmission lines, making mechanical actions compatible with the standardized towers that best suit the applications, thus avoiding the eventual use of oversized towers.

### Conductor Buffer

For the series of towers, we consider the cable buffer below, with this, we can guarantee that any need for cable variation in the Towers can be applied without impact and risk.

- CAA 795 Drake one conductor per phase
- CAA 636 Grosbeak two conductors per phase

Remembering that we must follow the criteria as a priority.

### Wire Ground Cable

The definition of the wire Ground was based on guidelines relating to short-circuit current (cc) and protection actuation time (t), with the following values being indicated by ENEL Grids Brazil:

- I<sub>cc</sub> 31 (kA)
- t 0.5 (s)

Therefore, the lightning cable that was defined as priority in its use is the OPGW Cable GSC 005/14 (25kA 48FO) global specification GSC-005 - High Voltage Line Overhead Ground Wire, thus following the global criteria and if it is necessary to complement this protection, another cable of the same specification can be used.

### EDS Traction

Starting tractions, EDS, without wind at 20° C, corresponding to 18% of the Breaking Load of the cables, both for conductors and lightning rods.

### Deflection angle variation range

0° - 5° - 15° - 30° - 60° - 90°

### Wind span variation range.

150.00 m - 300.00 m

### Wind speed and pressure

To calculate the design wind speed (V<sub>p</sub>), the procedure prescribed by NBR-5422 will be used, making the adjustments determined by the regulations, considering:

- Land category
- Integration period for cables
- Height of conductors and lightning rods

Therefore, for the values adopted in the project, the design wind speed of **V<sub>p</sub> = 38,9 m/s.**

	GLOBAL STANDARD	Page 46 of 94
	LATTICE STEEL SUPPORTS FOR HIGH VOLTAGE LINES	GSCS001 Rev. 01 05/02/2024

**Note:** We consider the basic wind speeds, for a return period  $T = 150$  years, and an integration time of 10.0 minutes, at 10.00 meters high.

### CRITERIA FOR MODELING LOADING TREES

Considering the diversity of variables involved in the composition of the load trees, and aiming to achieve the most severe load conditions for each structure, the set of towers was segmented into two categories, namely:

Series I one cable per phase towers T1, T2, T3, T4, T5

Series II two cables per phase towers T6, T7, T8, T9, T10

### DEFINITIVE LOAD TREES

In addition to the previous conditions and aiming to provide the towers with relative rigidity to possible unbalanced longitudinal loads, due to differences in spans behind and in front of the towers, longitudinal loads will be adopted for Hypothesis I, maximum transverse wind, coincident temperature and all cables intact. For the purpose of composing the definitive load trees, unbalanced longitudinal loads corresponding to 15% of the maximum traction in the hypothesis will be considered, both for the conductors and the lightning rods, resulting in the values indicated below:

#### Conductor

Tower T1 up to T3 - Unbalanced longitudinal effort 400 kgf

Towers T4 and T5 - Unbalanced longitudinal force 570 kgf

Towers T6 up to T10 - Unbalanced longitudinal force 960 kgf

#### Wire Ground

Towers T1 up to T10 - Unbalanced longitudinal force 340 kgf

### Table Codes:

TYPE CODE	CODE BRAZIL	TYPE TOWER	DESCRIPTION
GSCS001/T1	230399	T1	TORRE AUTOPORTANTE METÁLICA, TIPO T1, GSCS001
GSCS001/T2	230387	T2	TORRE AUTOPORTANTE METÁLICA, TIPO T2, GSCS001
GSCS001/T3	230390	T3	TORRE AUTOPORTANTE METÁLICA, TIPO T3, GSCS001
GSCS001/T4	230392	T4	TORRE AUTOPORTANTE METÁLICA, TIPO T4, GSCS001
GSCS001/T5	230391	T5	TORRE AUTOPORTANTE METÁLICA, TIPO T5, GSCS001
GSCS001/T6	230389	T6	TORRE AUTOPORTANTE METÁLICA, TIPO T6, GSCS001
GSCS001/XT7	230388	T7	TORRE AUTOPORTANTE METÁLICA, TIPO T7, GSCS001
GSCS001/T8	230386	T8	TORRE AUTOPORTANTE METÁLICA, TIPO T8, GSCS001
GSCS001/T9	230385	T9	TORRE AUTOPORTANTE METÁLICA, TIPO T9, GSCS001
GSCS001/T10	230384	T10	TORRE AUTOPORTANTE METÁLICA, TIPO T10, GSCS001

**Load Trees by Hypothesis – See Annex B**

	GLOBAL STANDARD	Page 47 of 94
	LATTICE STEEL SUPPORTS FOR HIGH VOLTAGE LINES	GSCS001 Rev. 01 05/02/2024

## LOCAL SECTION E – E–distribuzione

### ITALIAN STANDARD LATTICE TOWERS

Italian lattice tower used outside the CP are of three types:

- Sostegno a delta
- Sostegno a doppia bandiera
- Sostegno a semplice terna
- Palo Gatto
- Portale

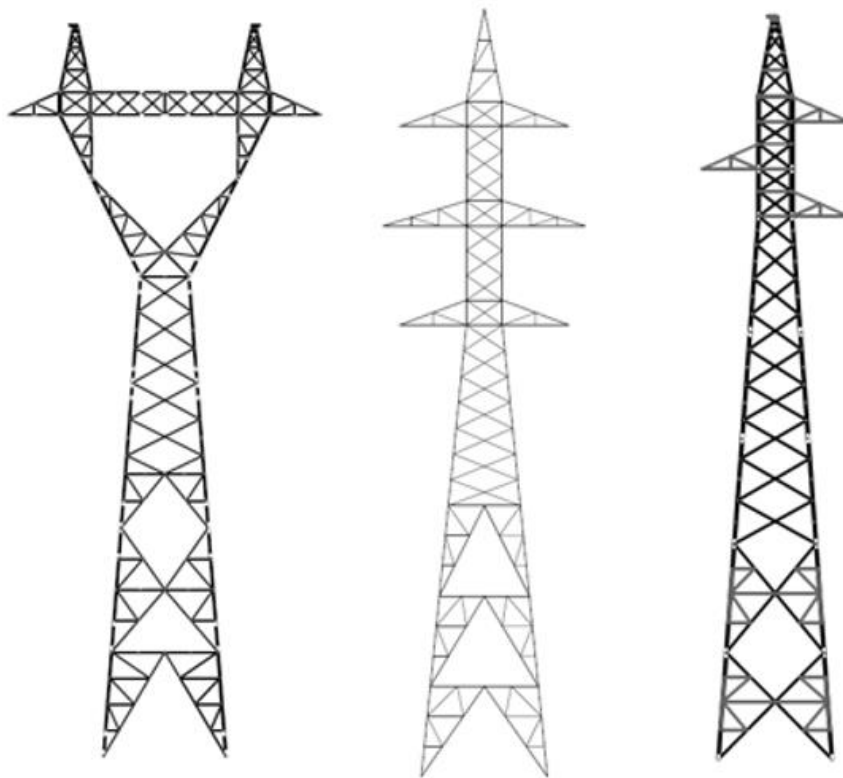

Fig. E 1 – Delta; doppia bandiera; semplice terna respectively

Another type of lattice tower, normally used in the Italia CP, is the type “Palo Gatto” as shown at Fig. E2, and portale type as shown in Fig E3:

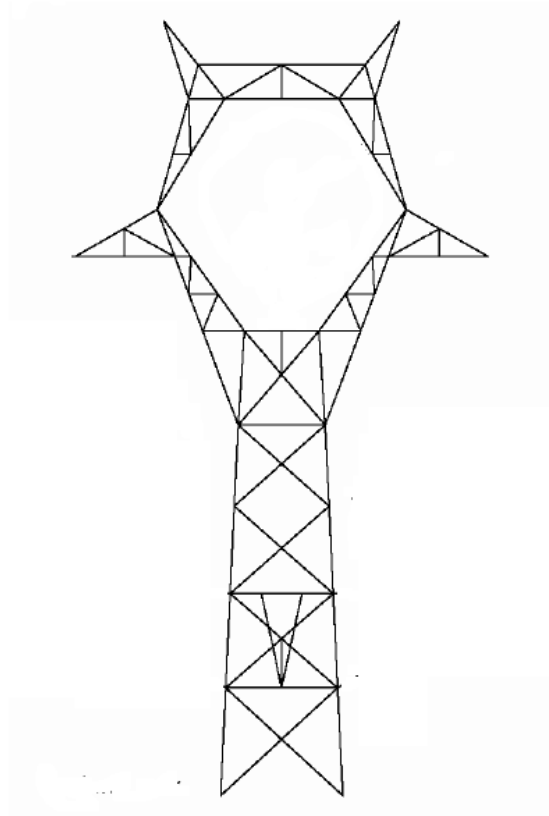

Fig. E2 – Palo Gatto

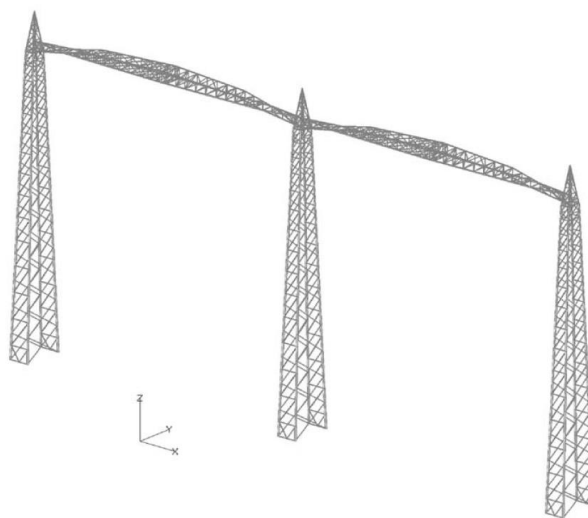

Fig. E3 – Portale



Lattice towers are normally verified according to the Utilization Diagram, span length vs selected angle of the tower with the respect to the axial overhead line route. If the selected lattice tower, shows on x axis Span length, and on y axis tower deviation angle, as shown at Fig. E4.

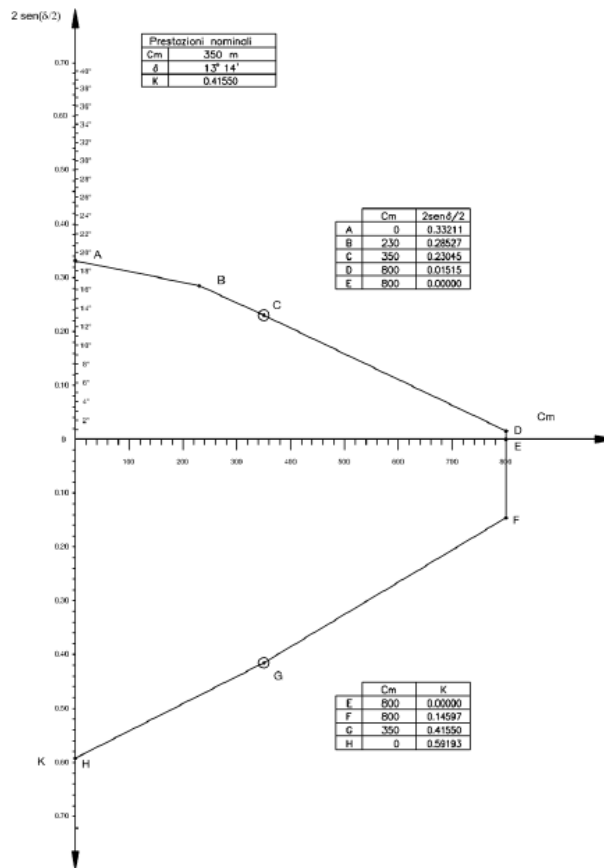

Fig E4 – Example of Italian Standard M Type Lattice Tower DT Full Load - Utilization Diagram

Structural design of lattice towers, in Italy, shall meet requirements of:

- CEI EN 50341-1
- CEI EN 50341-2-13

the use of NTC or Eurocodes shall be delivered according CEI EN 50341-2-13 requirements.

When designing an overhead line using statistical approach, 50 years reliability levels shall be considered:

level 1 - T = 50 years

	GLOBAL STANDARD	Page 50 of 94
	LATTICE STEEL SUPPORTS FOR HIGH VOLTAGE LINES	GSCS001 Rev. 01 05/02/2024

## ACTIONS ON OVERHEAD LINES

### Wind Load

Tower perpendicular wind load, considered respect to each component of the overhead line is given by:

$$Q_w = q_b C_e G_x C_x A$$

- $q_b$  = Dynamic wind pressure
- $a_s$  is the quote above sea level. For  $a_s > 1.500$  m  $a_s$  is considered = 1.500 m.
- $C_e$  = gust response factor
- $G_x$  = Aerodynamic drag factor
- $C_x$  = Dynamic aerodynamic drag factor

Element	C
Conductors	1
Aerial stranded conductors	1
Overhead cables	1
Cylindrical bars and cylindrical tubular poles	0,8
Bars, tubular poles with more than six sides	1,2
Bars, tubular poles with six sides	1,4
Flat surfaces perpendicular to wind direction (corner, poles with rectangular section)	1,8
Spherical parts	0,35
Insulators	1,2

Table E1 - Dynamic aerodynamic drag factor

### Ice Load

Ice load is centered on the estimate of the characteristic thickness of the ice/snow sleeve that forms on the conductor, assuming a return time of 50 years and that the sleeve is cylindrical in shape with a circular section. This paragraph indicates the reference thickness of the ice or snow  $S_k$  that settles on the conductors with a return period of 50 year, if the sleeve has a cylindrical shape with a circular section. For any height above 1.500m of see level,  $a_s$  shall be considered as equal to 1.500 m.

	GLOBAL STANDARD	Page 51 of 94
	LATTICE STEEL SUPPORTS FOR HIGH VOLTAGE LINES	GSCS001 Rev. 01 05/02/2024

Type of load	Regions	Ice/snow density [kg/mc]	as ≤ 600 m [mm]	as > 600 m [mm]
1	Valle d'Aosta, Piemonte, Liguria, Lombardia, Trentino Alto Adige, Emilia Romagna, Friuli Venezia Giulia, Veneto, Abruzzo e Molise (se as > 600m)	900	0	18+16(as-600)/1000
2	Valle d'Aosta, Piemonte, Liguria, Lombardia, Trentino Alto Adige, Emilia Romagna, Friuli Venezia Giulia, Veneto, Emilia Romagna, Marche, Abruzzo, Molise, Umbria, Toscana (escluse province di Pisa, Livorno, Grosseto), Lazio (escluse province di Viterbo, Roma, Latina), Campania (escluse province di Napoli, Caserta), Puglia (escluse province di Brindisi, Lecce), Basilicata, Calabria (escluse province di Vibo Valentia, Reggio Calabria)	500	24	24+20(as-600)/1000
3	Sicilia, Sardegna, Province di Pisa, Livorno, Grosseto, Viterbo, Roma, Latina, Napoli, Caserta, Brindisi, Lecce, Vibo Valentia, Reggio Calabria)	500	0	20+15(as-600)/1000

Table E2 – Regional Type of Ice load

### Wind and Ice/Snow load combinations

Towers shall withstand mixed load, as indicated in Tab E3

Conditions		Temperature [°C]	Wind speed [m/s]	Ice/snow thickness [mm]
a)	Every Day Stress	15	0	0
b)	Minimum temperature	Zone A -7	$\sqrt{C_e} V_b$	0
		Zone B -20	$0,76 \sqrt{C_e} V_b$	
c)	Wind load	-7	$\sqrt{C_e} V_b$	0
d)	Wind and ice/snow load combinations (*)	-2	0,6 V <sub>b</sub>	Sk
e)				
f1)	Verification of the insulation distances - maximum temperature method	Zone A 75	0	0
		Zone B 75		
f2)	Verification of the insulation distances - limit state method	Zone A 55	0	0
		Zone B 48		
f3)	Verification of insulation distances in extreme temperature conditions - limit state method	96	0	0
g)	Verification of safety electrical distance in conditions of slanted catenary	Zone A 55	0	0
		Zone B 48		
(*) This check is not applicable to areas in which Sk=0 (areas in which type 3 load is expected for as ≤ 0. In areas in which both type 1 and type 2 loads are expected, it is necessary to carry out both checks .				
The temperature values for tests f1), f2), f3), g) relating to conductors with high thermal limits must be indicated in the project specifications.				

Tab E3 – Mixed loads

- Zone A = altitude above sea level less than or equal to 800 m Italy central regions, island, and southern Italian regions; the minimum T is -7°C
- Zone B = altitude above sea level greater than 800 m in the central, island and southern Italian regions as well as all of northern Italy; the minimum T is -20 °C.

Safety structural load Loads shall be verified according CEI EN 50341-2-13 (Cap. 4)

	GLOBAL STANDARD	Page 52 of 94
	LATTICE STEEL SUPPORTS FOR HIGH VOLTAGE LINES	GSCS001 Rev. 01 05/02/2024

### Seismic Calculation

Ground acceleration due to earthquakes may influence the design of rigid and heavy concrete structures. NNA shall be considered in Lattice Tower selection and OHL design.

Seismic loads which may lead to additional loading forces may be considered for each lattice tower. These considerations may include the natural period of vibration of the structure, the site structure resonance factor (depending on the soil conditions), and the height, weight, and mass distribution of the support structure. Since the frequency of the support is higher than that of the conductors, the dynamic load from the conductors will not be significant.

Conversely, no important effects from the support relative to conductors should be expected. CEI EN 50341-1 and CEI EN 50341-2-13 (NNA for Italy) states that seismic verification shall be executed according to the following conditions:

<b><i>Temperature with Ice and Snow</i></b>
Temperature of -20°C with no Ice or Snow load
Temperature of -2°C with Ice or Snow load
<b><i>Temperature with no Ice and Snow</i></b>
Temperature of -7°C

Partial load factors shall be considered = 1. For every lattice tower and its foundation, NTC 2018 verification shall be applied.

### USABILITY OF TERNA STANDARD LATTICE TOWERS FOR E-DISTRIBUZIONE

E-Distribuzione accepts the use of Terna standard lattice Towers ( ex. type L,N,M,P,E,C,V and “Palo Gatto”). In case of Terna standard lattice towers, E-Distribuzione will accept only towers able to withstand all technical requirements stated in Local Section E of ENEL GSCS001.

	GLOBAL STANDARD	Page 53 of 94
	LATTICE STEEL SUPPORTS FOR HIGH VOLTAGE LINES	GSCS001 Rev. 01 05/02/2024

## LOCAL SECTION F – Edistribución Redes Digitales

### CABLE TRANSITION TOWERS.

These towers will be designed to hold the transition of an overhead line to an underground line.

All circuits are converted from overhead to underground, so, mechanically, the function of the tower in the line is terminal or end of line, as described on paragraph 5.3.

They must be designed to support cable terminations and sheath voltage limiters on crossarms or additional arrangements. Terminations and sheath voltage limiters must be installed on a position lower than the nude conductor that received to avoid undesired contact with wildlife and at a distance equal or greater than 1.5 m to elements of any crossarm, apart from their own crossarm or platform.

Termination could be installed with an inclination from the vertical axis smaller than 30°.

At the same time, cable transition towers must provide support and protection to the underground cables from the ground level to the termination, including any means to hold them securely to the tower.

Minimum radius of curvature of cables must be respected.

From above the ground level to a minimum height of 2,5 m , cables must be protected by a metallic case or tube, sealed to avoid water penetration.

Cable transition towers include the code CON after the three-letter code in their denomination according to paragraph 6.

As an example:

**DF-1 CON 30-15 15m:** Indicates a support for double circuit type F-1 with 3 m. of distance between conductors, crossarms of at least 1.5 m. in length, and a useful height of 15 m, prepared to support the transition of six conductors to six cable underground.

### TOWERS FOR DERIVATION.

These towers are used to connect two lines as indicated on the drawing.

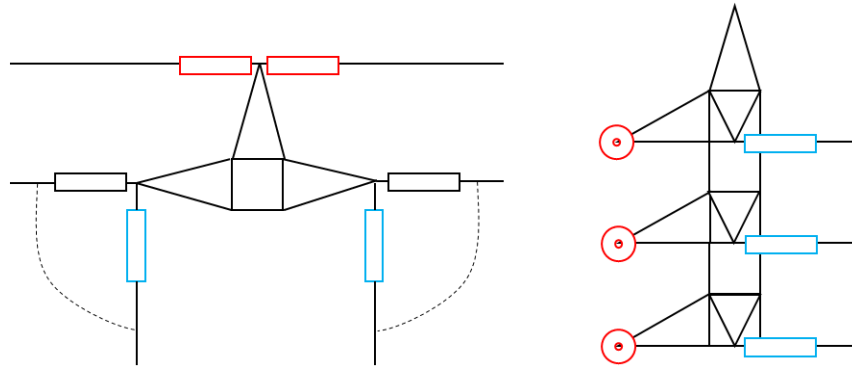

Connection scheme for a derivation tower.

They need tree additional crossarms to hold the circuit not involved in the derivation (red isolator). The minimum length of those crossarms is indicated on the table below:

Tower Type Group	Unified voltage values (kV)	Length of additional crossarm (m)
A	220	5,50
B	150	3,50
	138	
	132	
	115	
	110	
C	69	2,60
	66	
	45	

The attachment point for earth wire will be designed with three holes prepared for horizontal chains and an additional hole prepared for vertical chains.

Derivation towers include the code ENT after the three-letter code in their denomination according to paragraph 6.

As an example:

**DF-1 ENT 30-15 15m:** Indicates a support for double circuit type F-1 with 3 m. of distance between conductors, crossarms of at least 1.5 m. in length, and a useful height of 15 m, with tree additional crossarms of at least 2.6 m in length.

	GLOBAL STANDARD	Page 55 of 94
	LATTICE STEEL SUPPORTS FOR HIGH VOLTAGE LINES	GSCS001 Rev. 01 05/02/2024

**LOCAL SECTION H – Edesur**

## ANNEX A – STANDARD GRAPHS

The standard graphs included on this annex are those indicated on the table below:

Graphic Title	Load Case	C.S.	Types of Tower
Graph 1: Tower Type L and M	Load Case 1 (Wind)	1,5	L-0, L-1, L-2, L-3, M-0, M-1, M-2, M-3, M-4
Graph 1: Tower Type G and F	Load Case 1 (Wind)	1,5	G-1, G-2, G-3, G-5, G-6, F-1, F-2, F-3, F-4, F-5
Graph 1 bis: Tower Type L and M	Load Case 1 (Wind)	1,875	L-0, L-1, L-2, L-3, M-0, M-1, M-2, M-3, M-4
Graph 1 bis: Tower Type G and F	Load Case 1 (Wind)	1,875	G-1, G-2, G-3, G-5, G-6, F-1, F-2, F-3, F-4, F-5
Graph 2: Tower Type L and M	Load Case 2 (Ice, unbalanced tension)	1,2	L-0, L-1, L-2, L-3, M-0, M-1, M-2, M-3, M-4
Graph 2: Tower Type G and F	Load Case 2 (Ice, unbalanced tension)	1,2	G-1, G-2, G-3, G-5, G-6, F-1, F-2, F-3, F-4, F-5
Graph 3: Tower Type L and M	Load Case 3 (break of conductor)	1,2	L-0, L-1, L-2, L-3, M-0, M-1, M-2, M-3, M-4
Graph 3: Tower Type G and F	Load Case 3 (break of conductor)	1,2	G-1, G-2, G-3, G-5, G-6, F-1, F-2, F-3, F-4, F-5
Graph 4: Tower Type L and M	Load Case 4 (break of earth wire)	1,2	L-0, L-1, L-2, L-3, M-0, M-1, M-2, M-3, M-4
Graph 4: Tower Type G and F	Load Case 4 (break of earth wire)	1,2	G-1, G-2, G-3, G-5, G-6, F-1, F-2, F-3, F-4, F-5
Graph 3 (End of Line Funtion): Tower Type F	Load Case 3F (break of conductor, end of line funtion)	1,2	F-1, F-2, F-3, F-4, F-5
Graph 4 (End of Line Funtion): Tower Type F	Load Case 4F (break of earth wire, end of line funtion)	1,2	F-1, F-2, F-3, F-4, F-5





**Graph 1: Tower Type L and M**

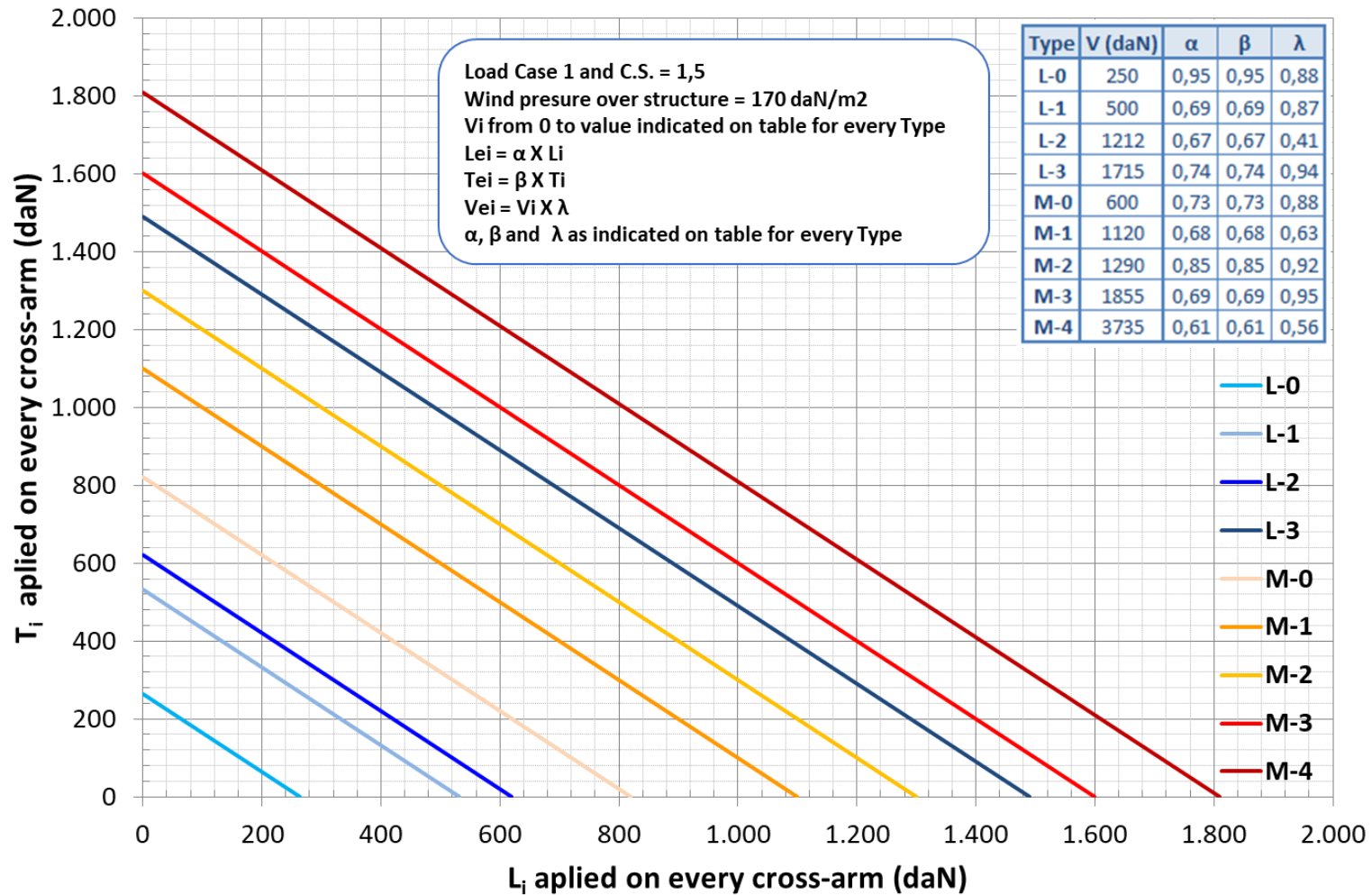



**Graph 1: Tower Type G and F**

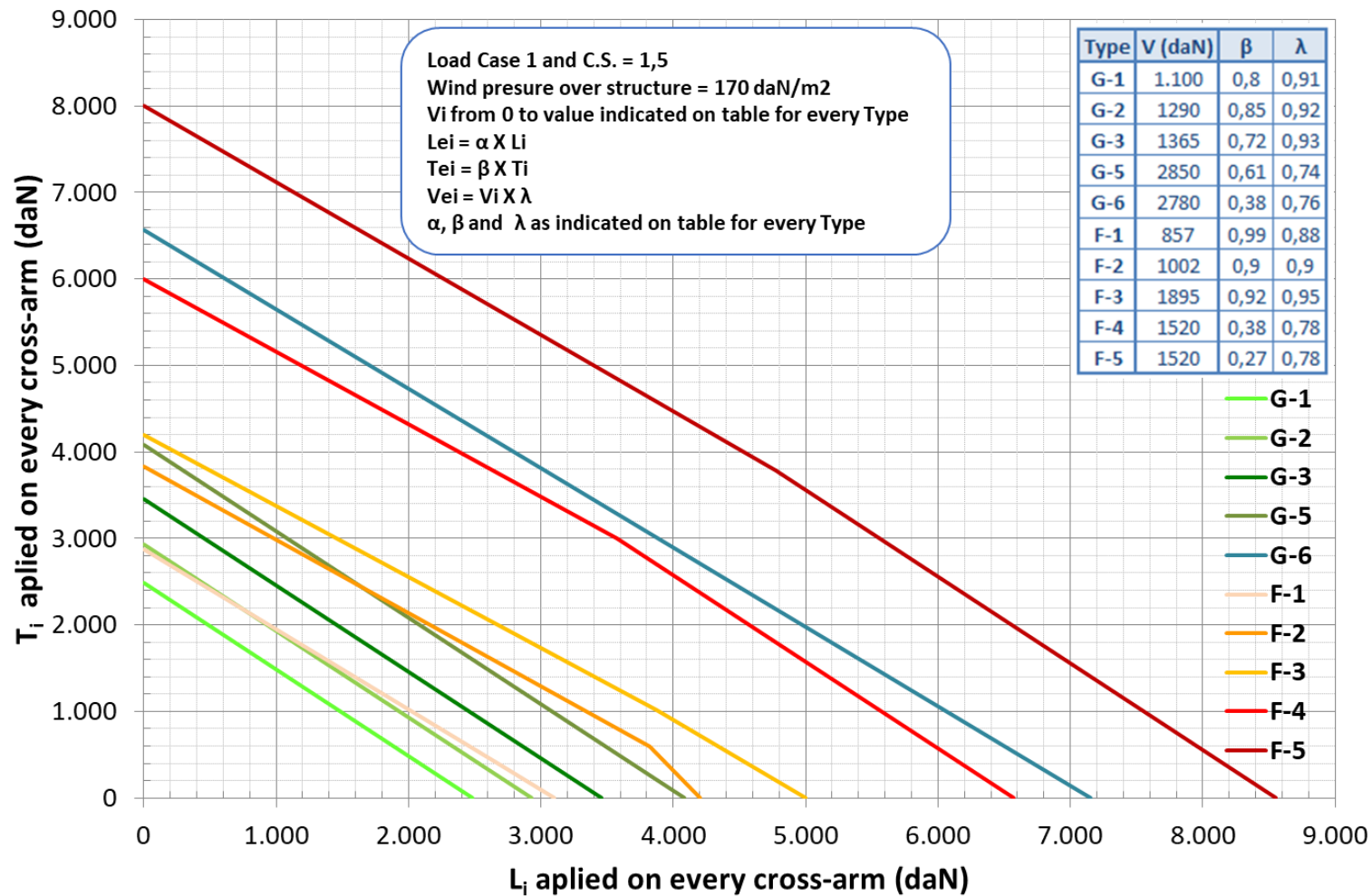



**Graph 1 bis: Tower Type L and M**

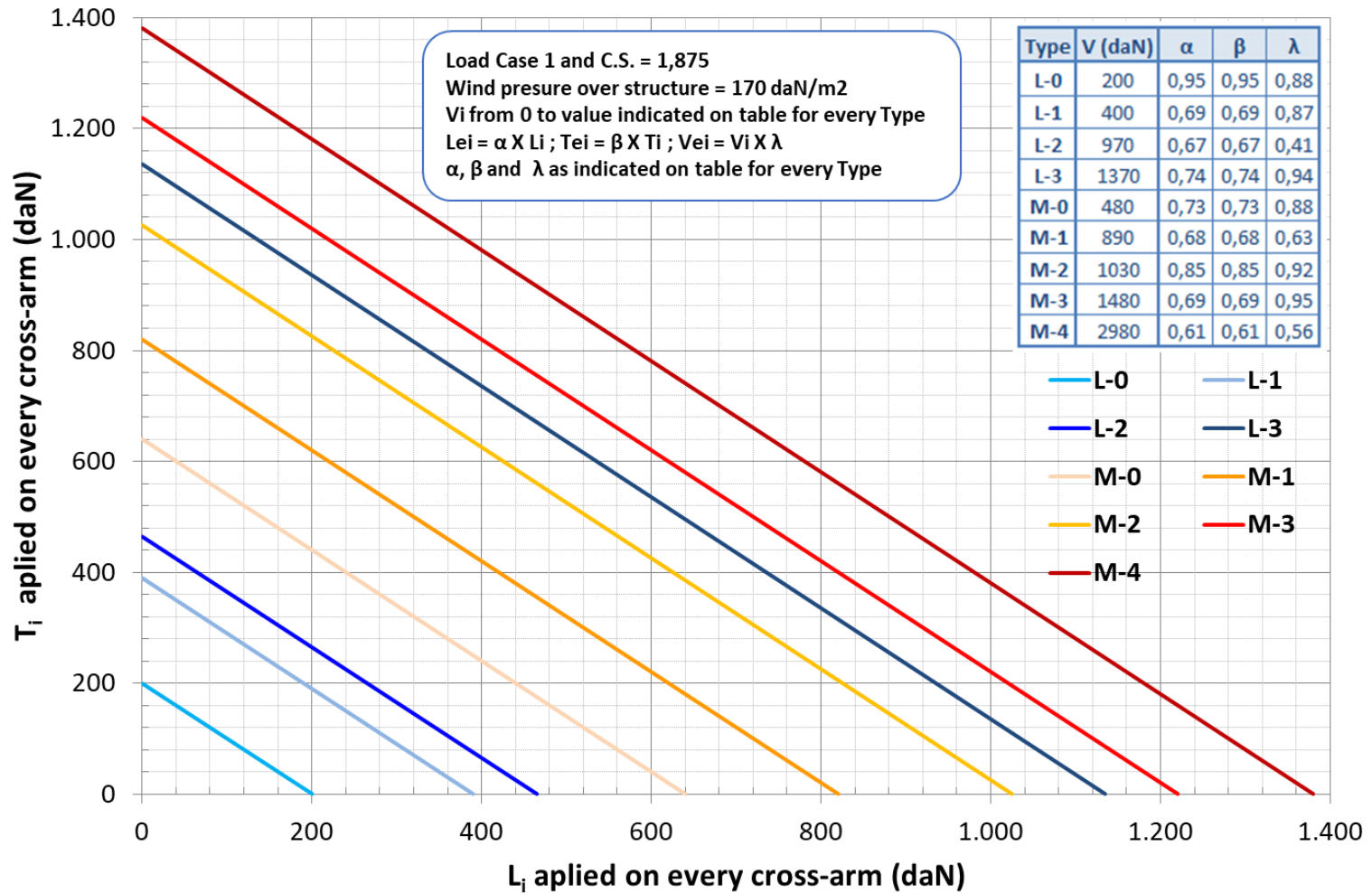



**Graph 1 bis: Tower Type G and F**

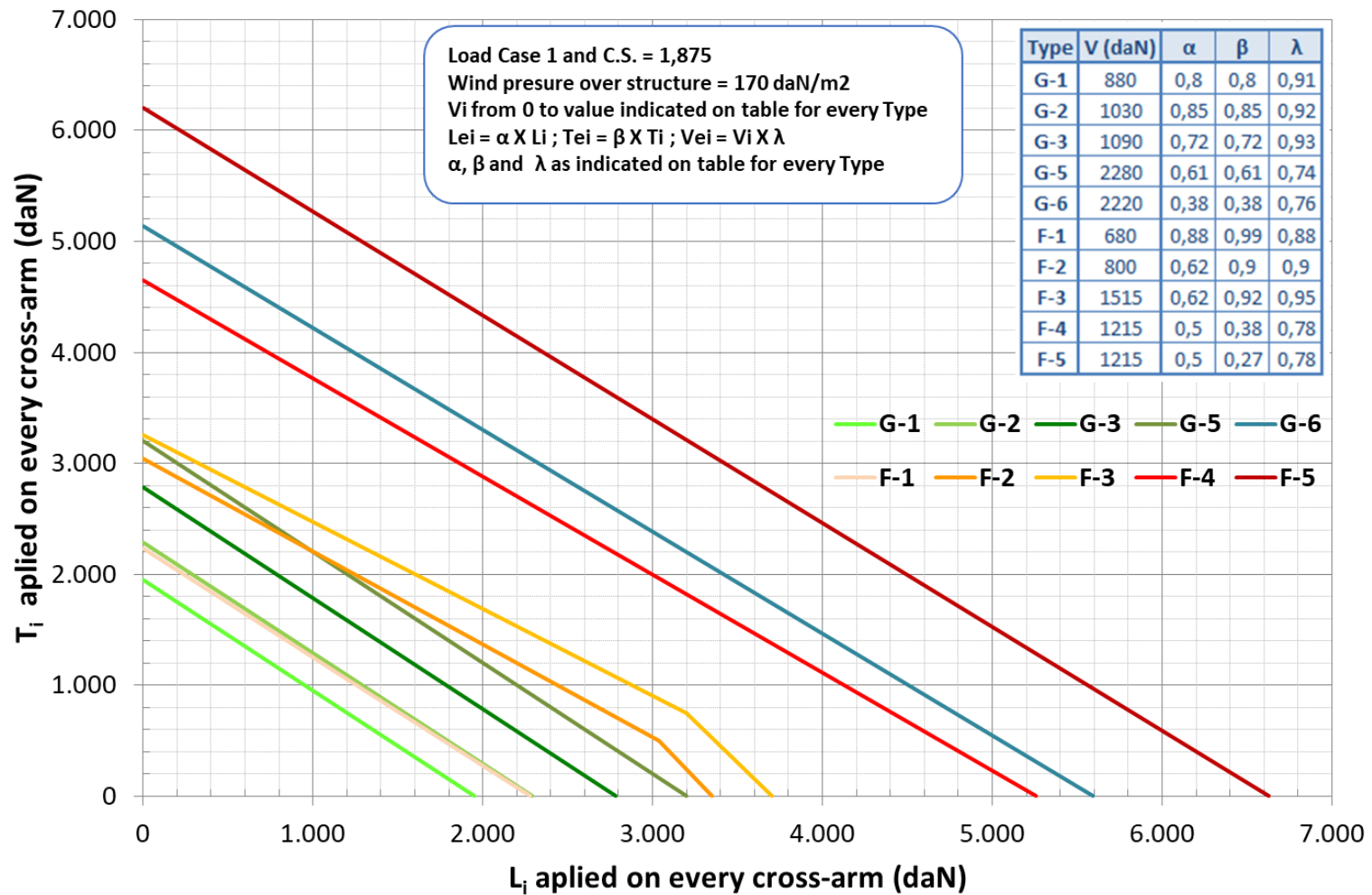



**Graph 2: Tower Type L and M**

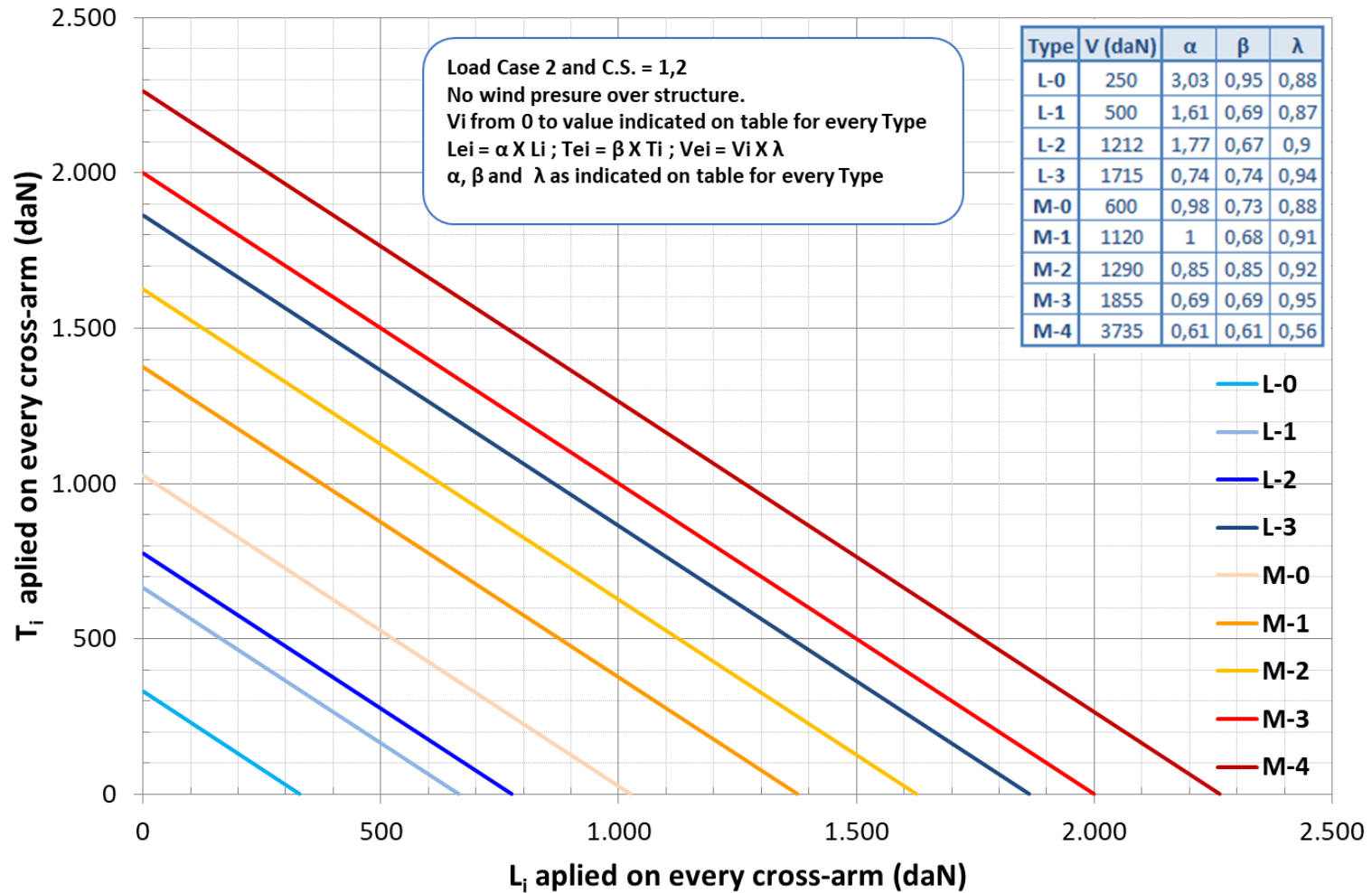



**Graph 2: Tower Type G and F**

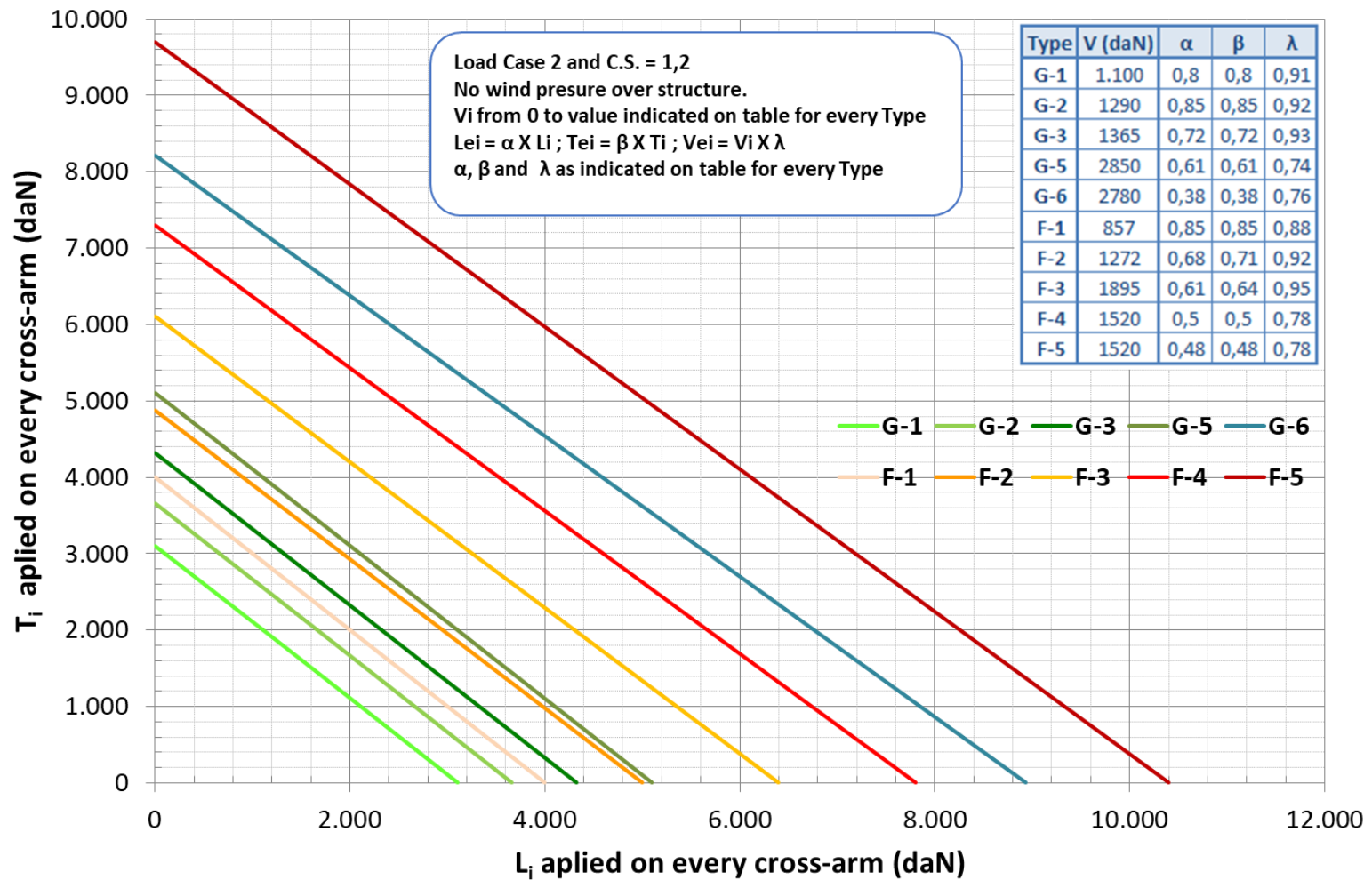



**Graph 3: Tower Type L and M**

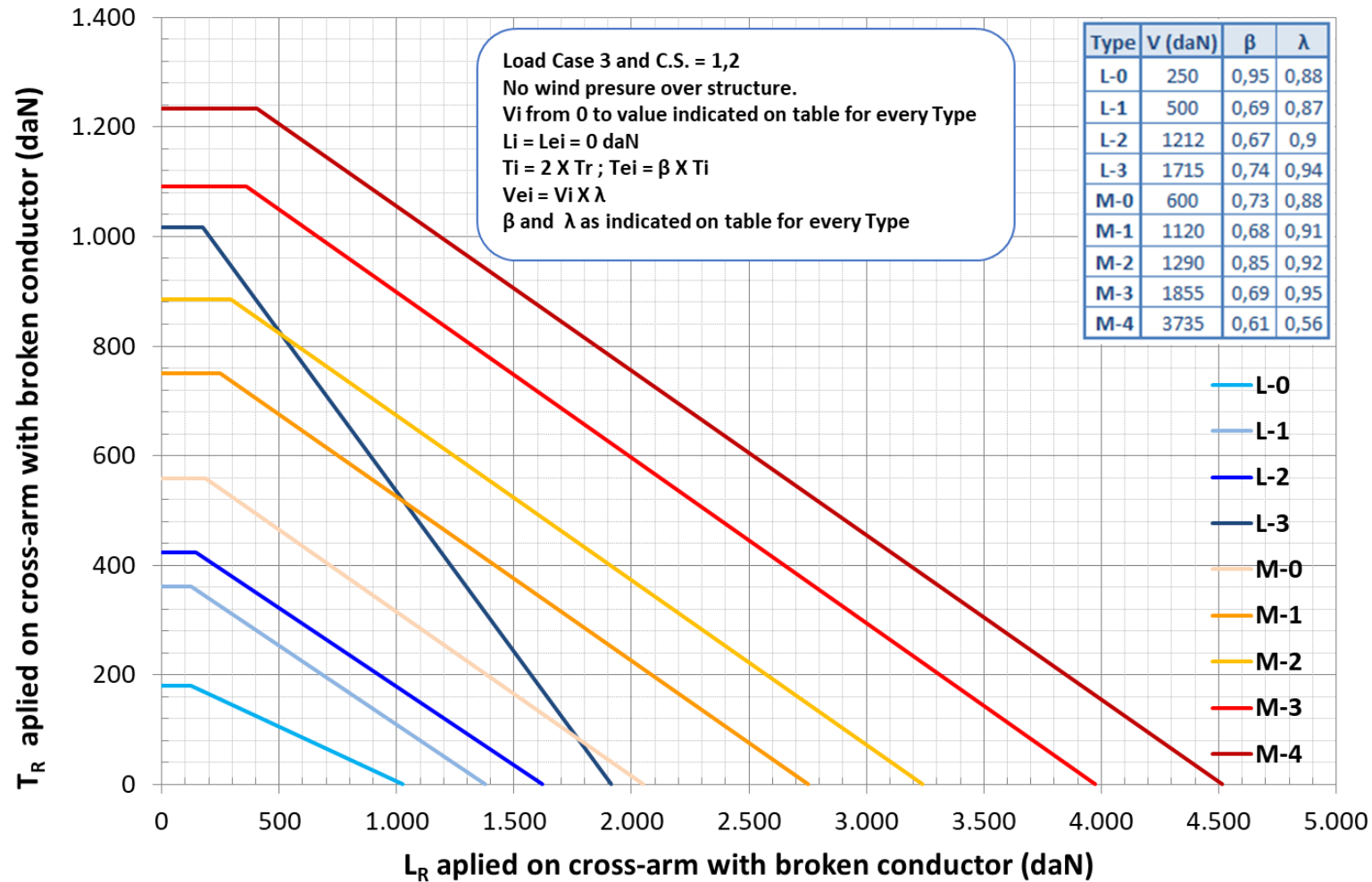



**Graph 3: Tower Type G and F**

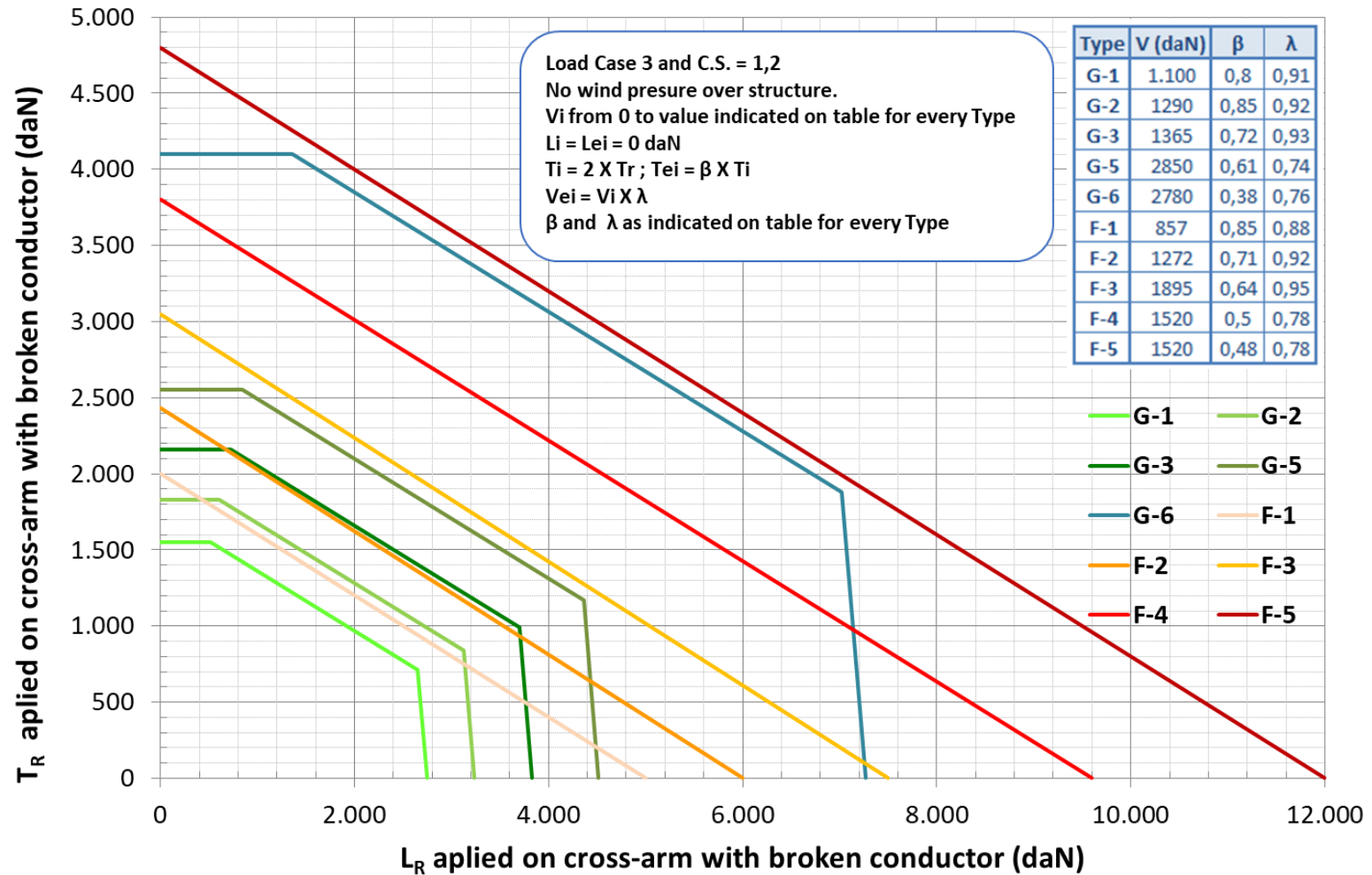





Graph 4: Tower Type L and M

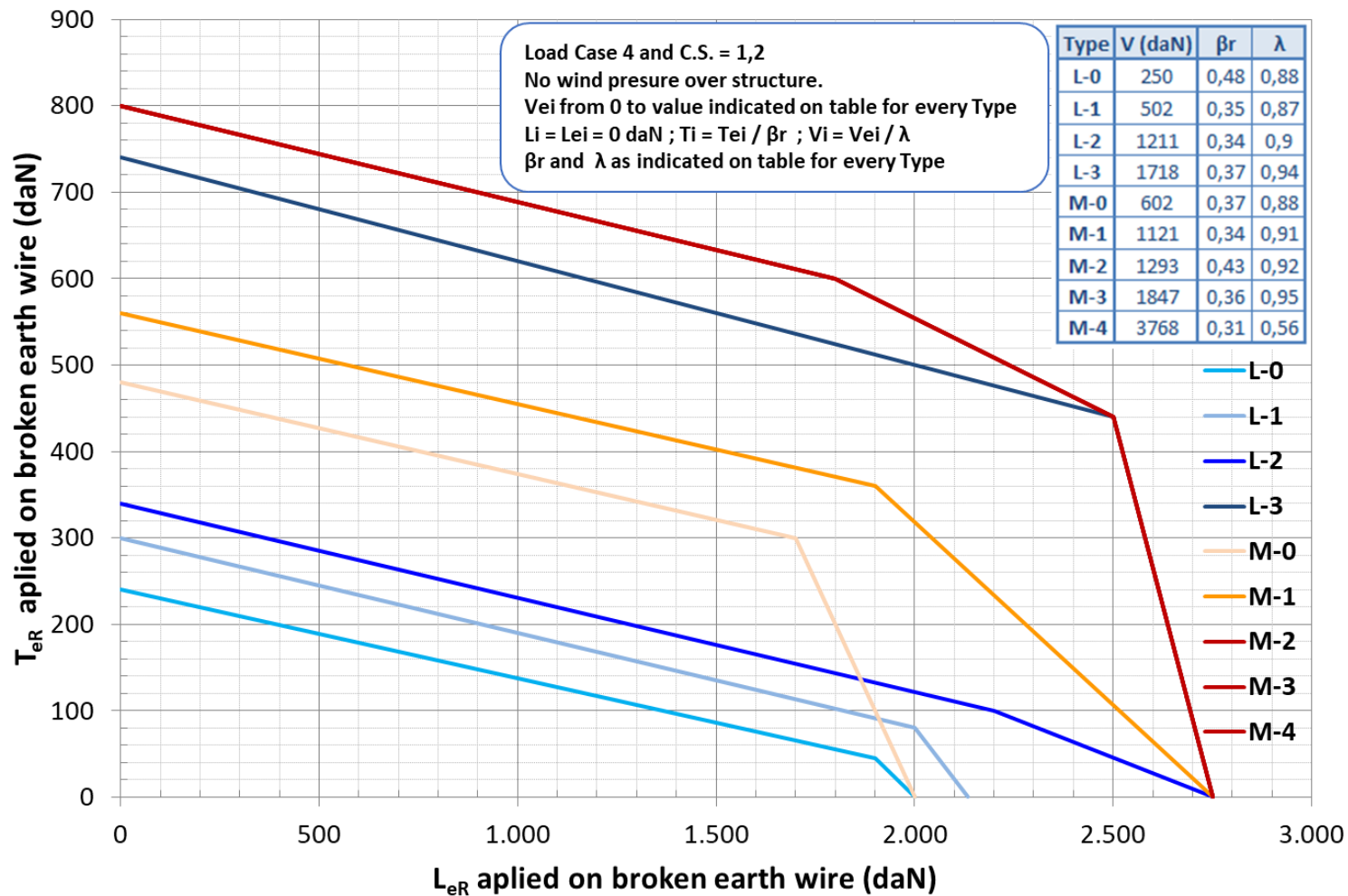



**Graph 4: Tower Type G and F**

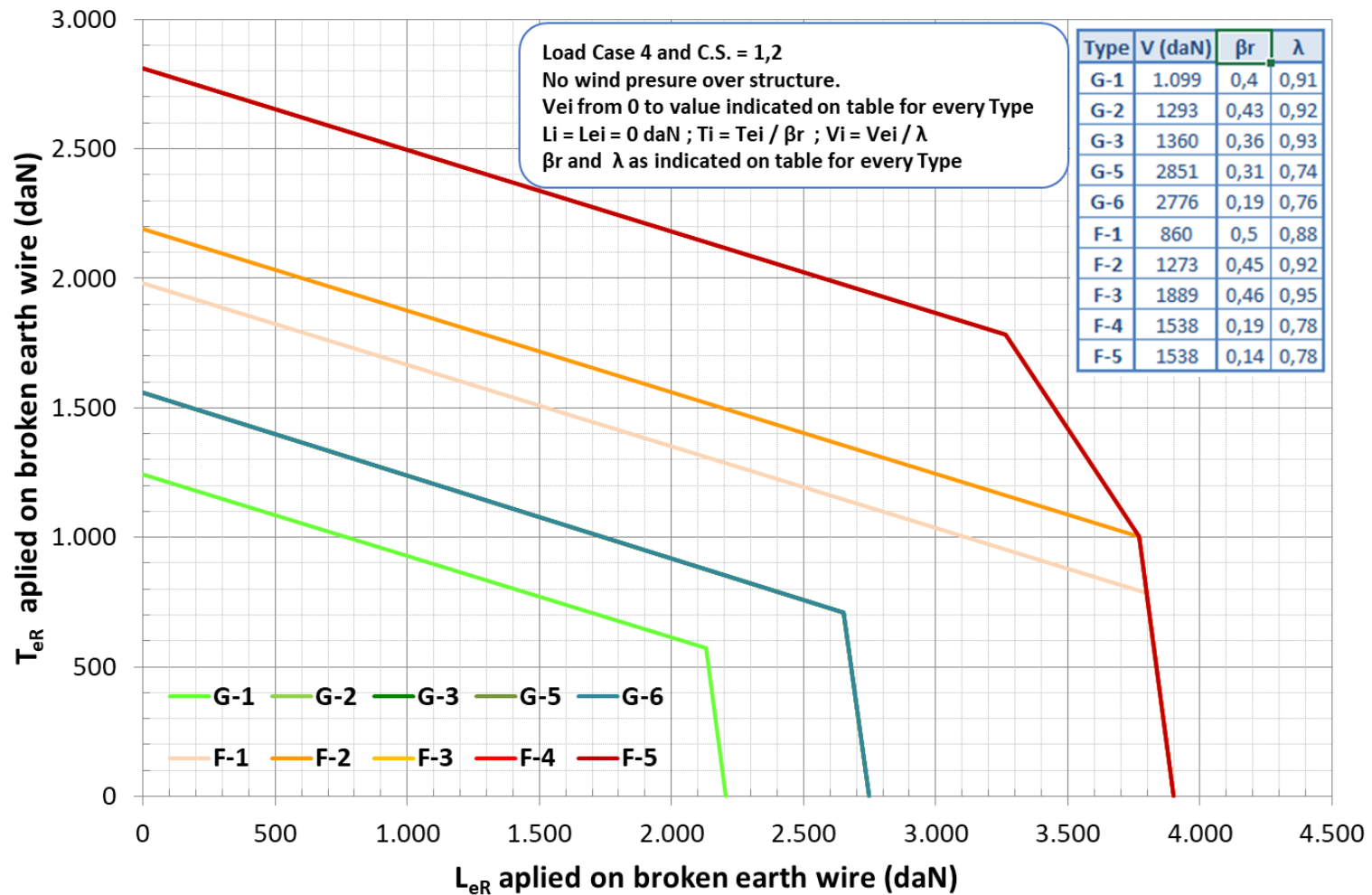



**Graph 3 (End of Line Funtion): Tower Type F**

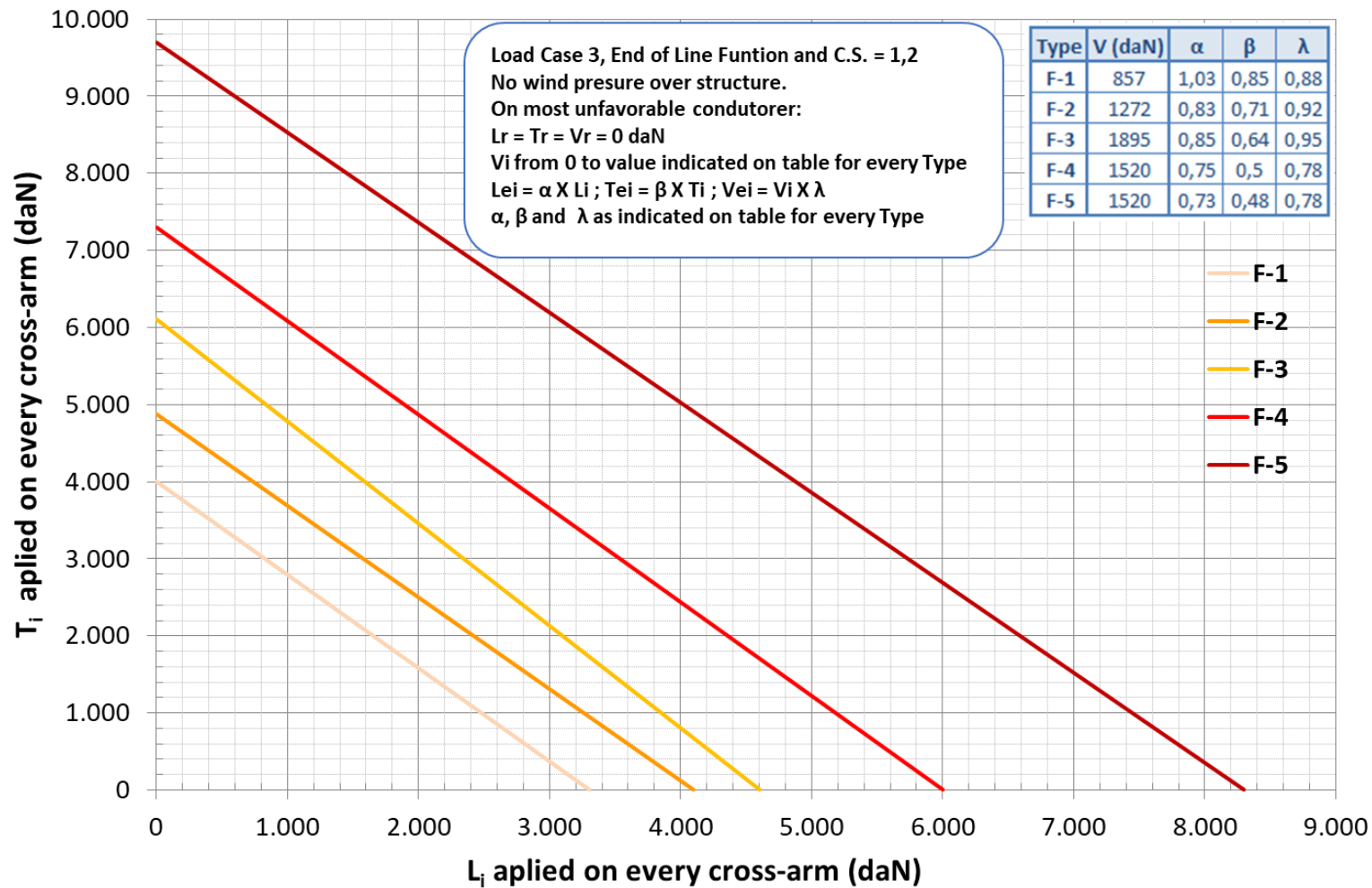



Graph 4 (End of Line Funtion): Tower Type F

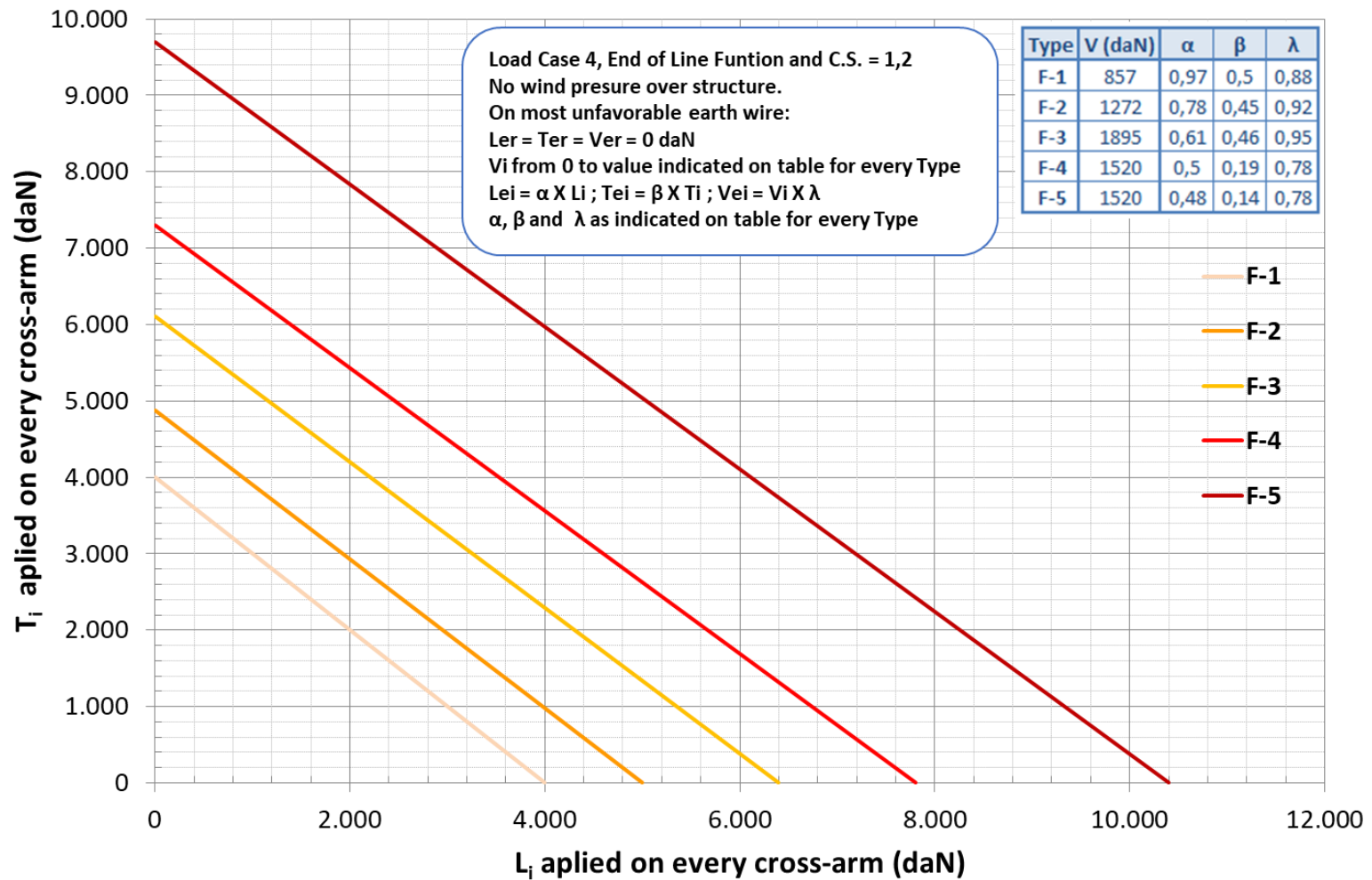

ANNEX B – Load trees for Brazilian Towers

Torre T.01

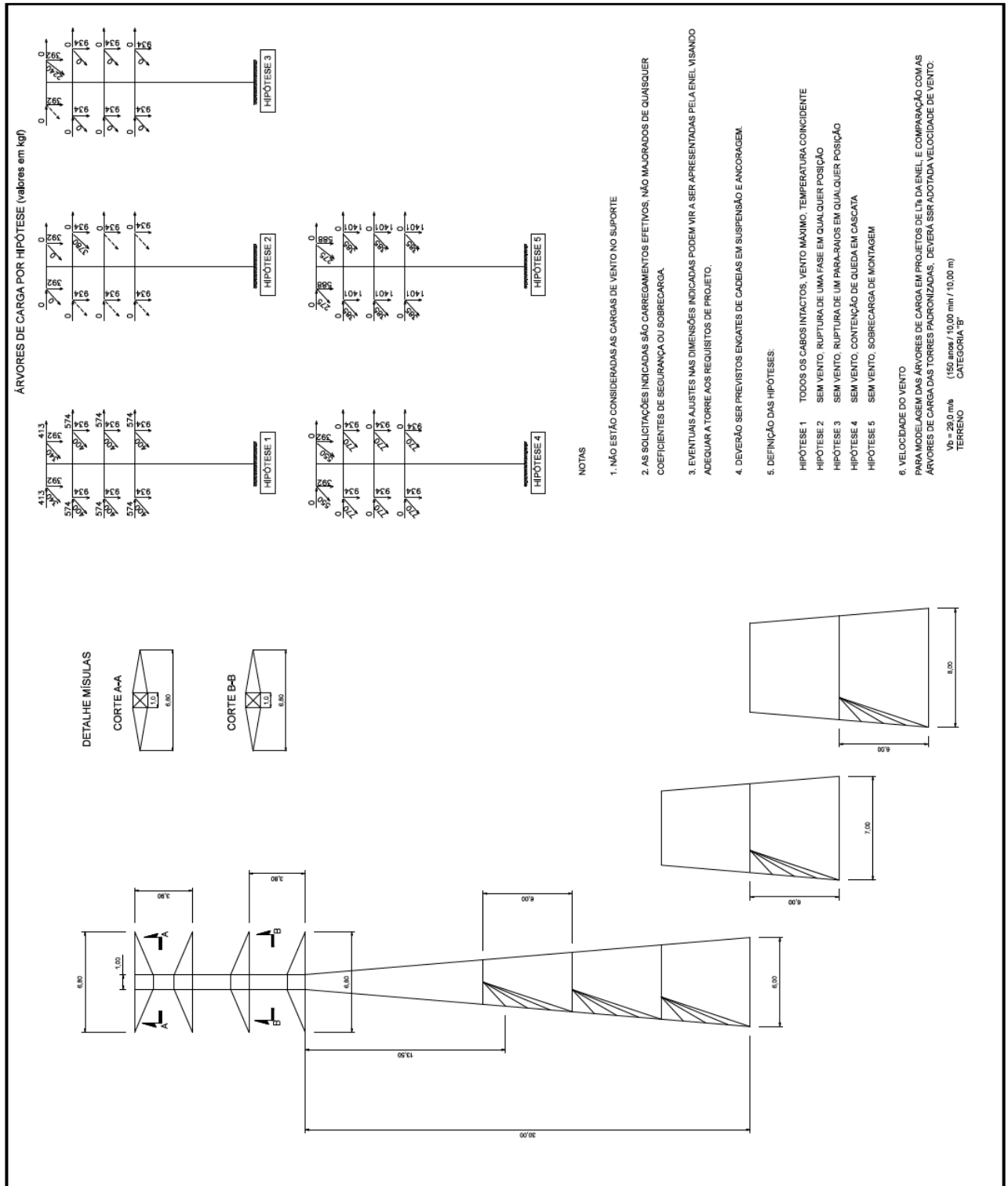



Torre T.02

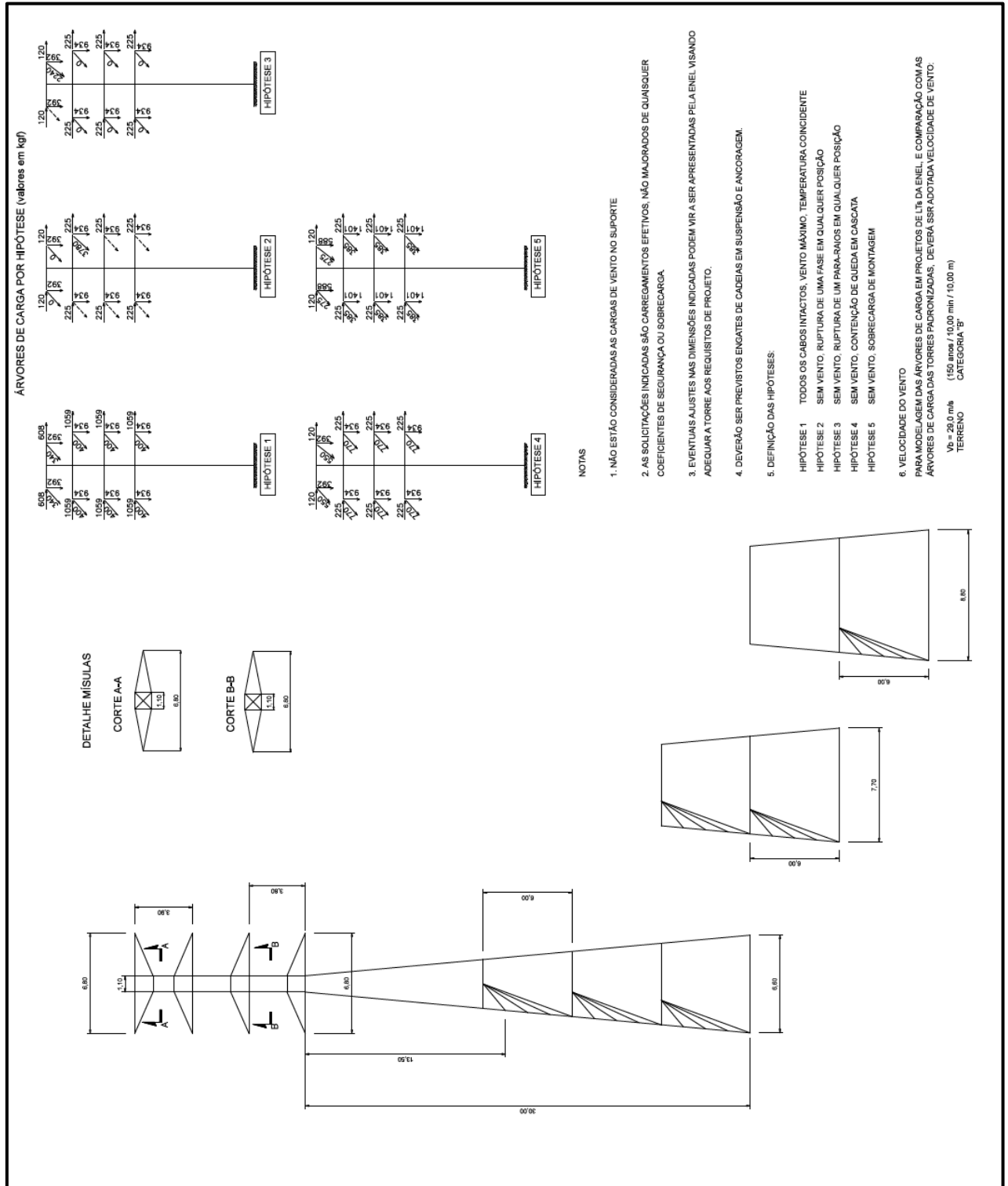



Torre T.03

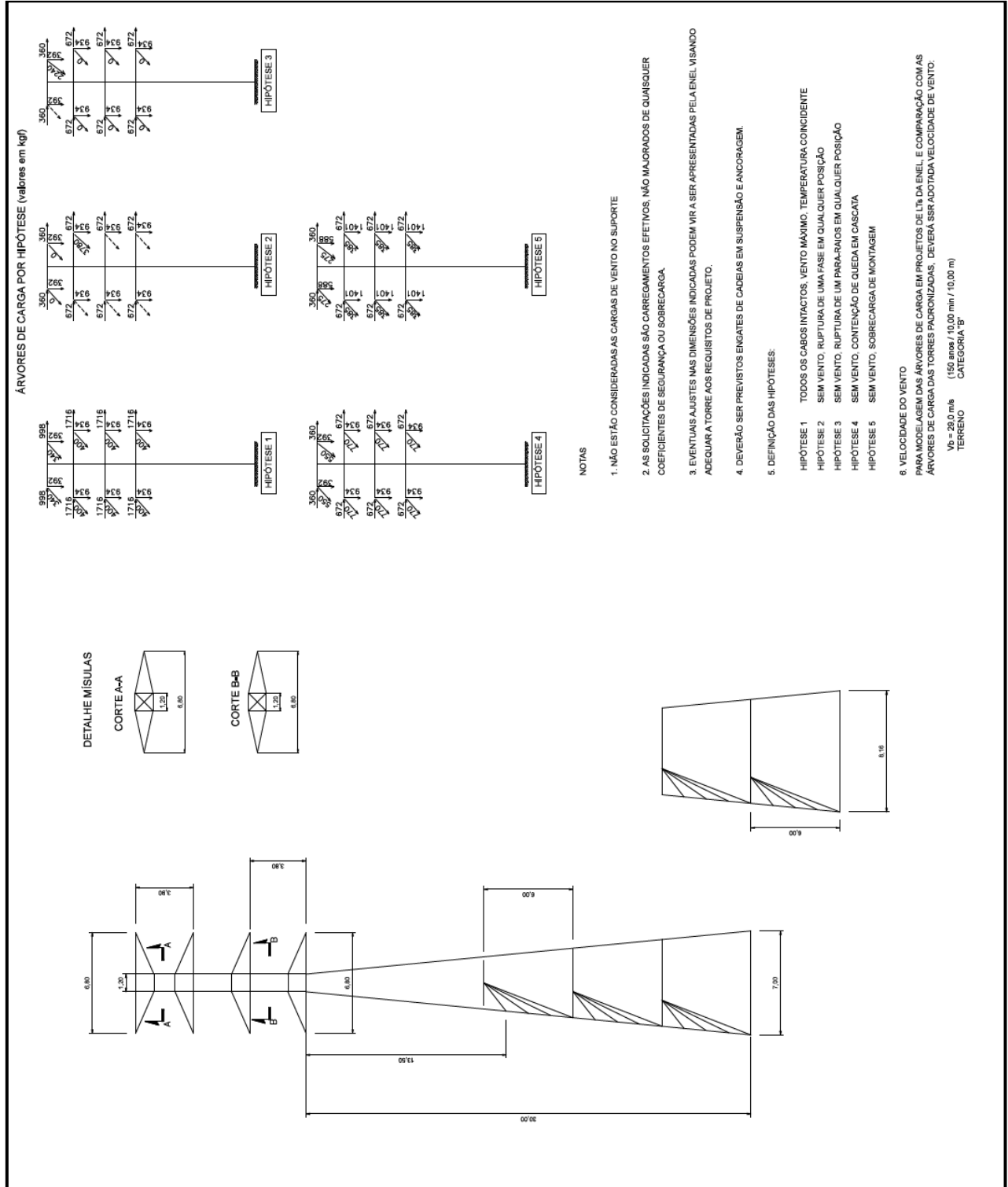



Torre T.04

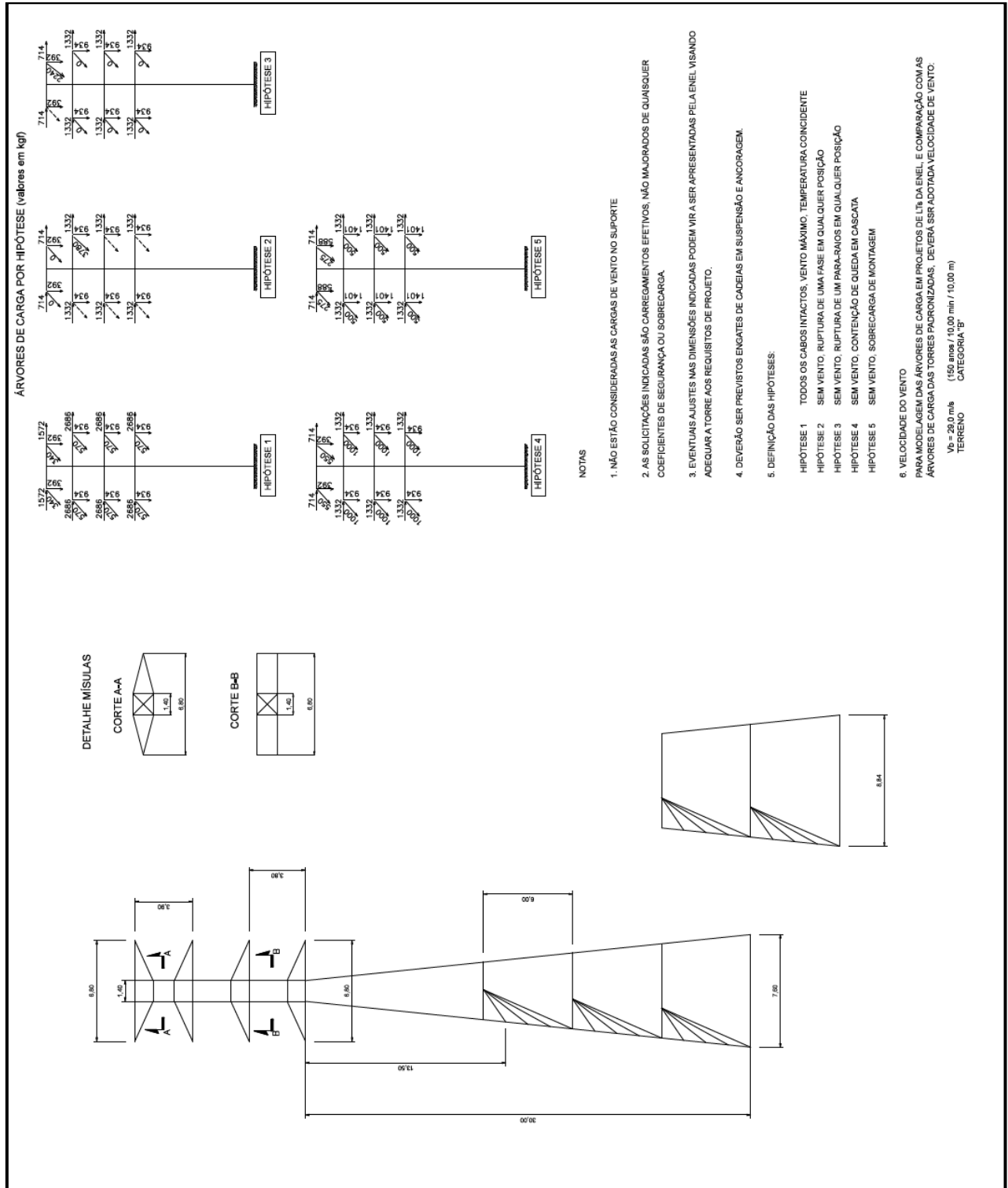



## Torre T.05

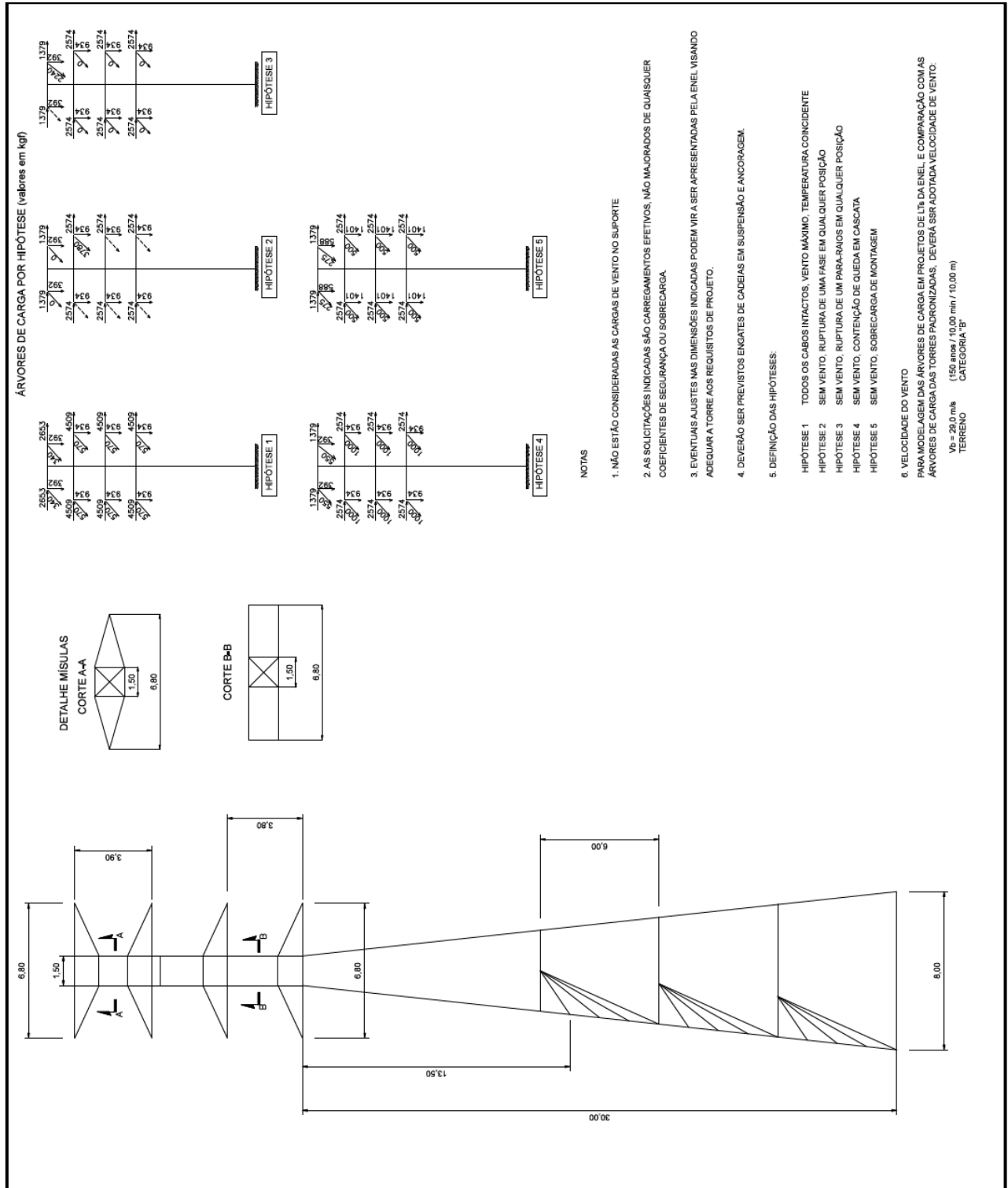



Torre T.06

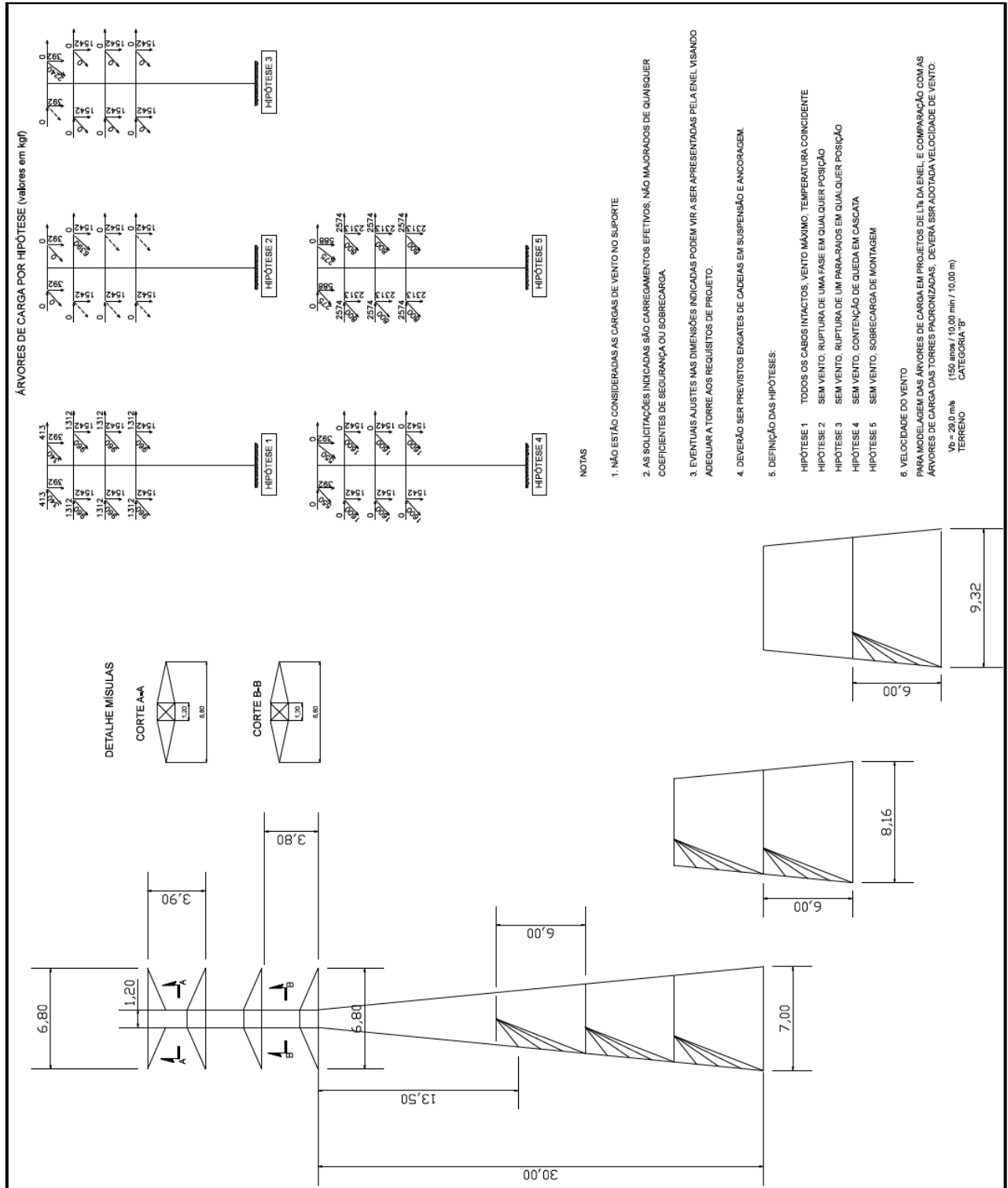



Torre T.07

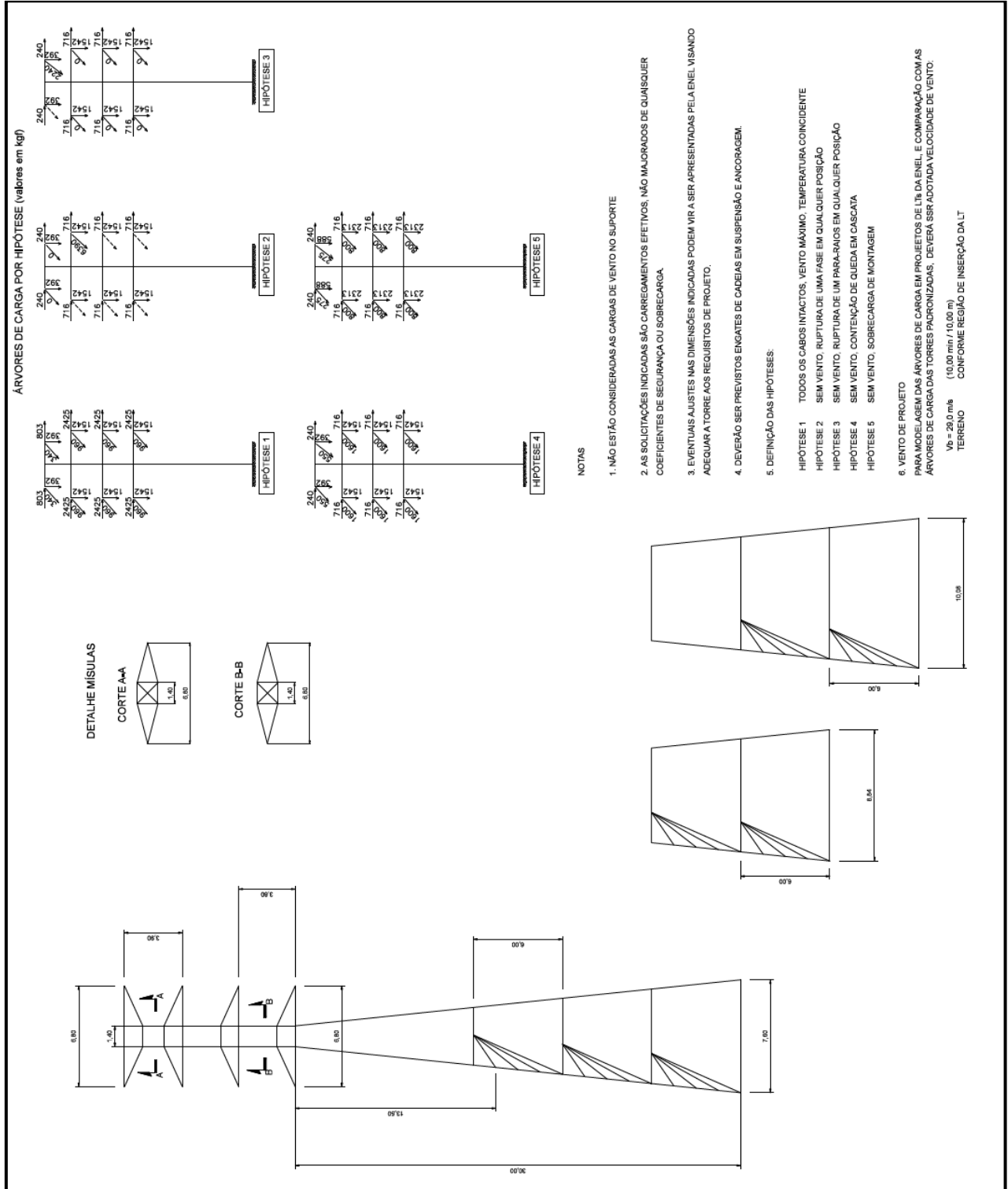



Torre T.08

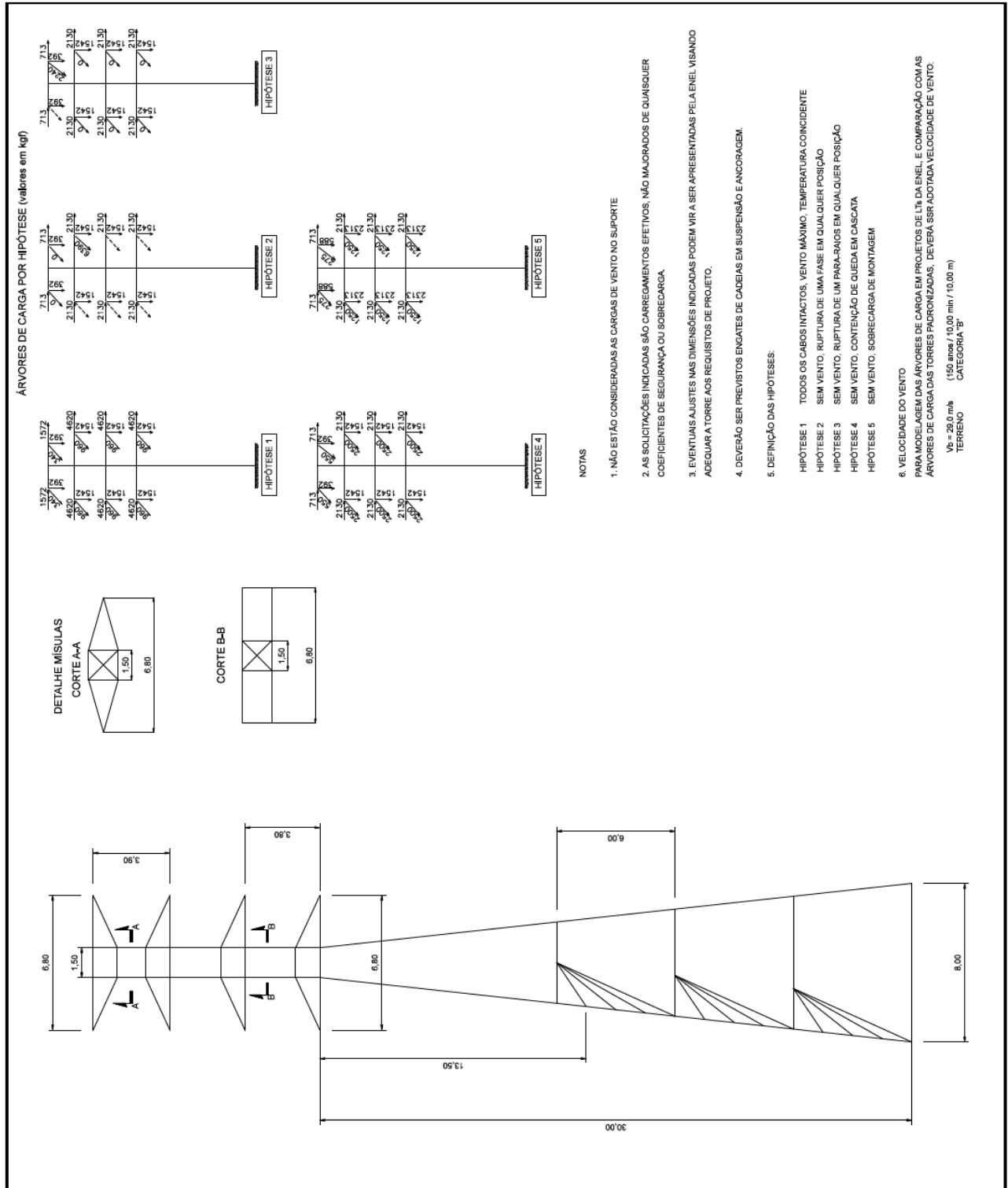



Torre T.09

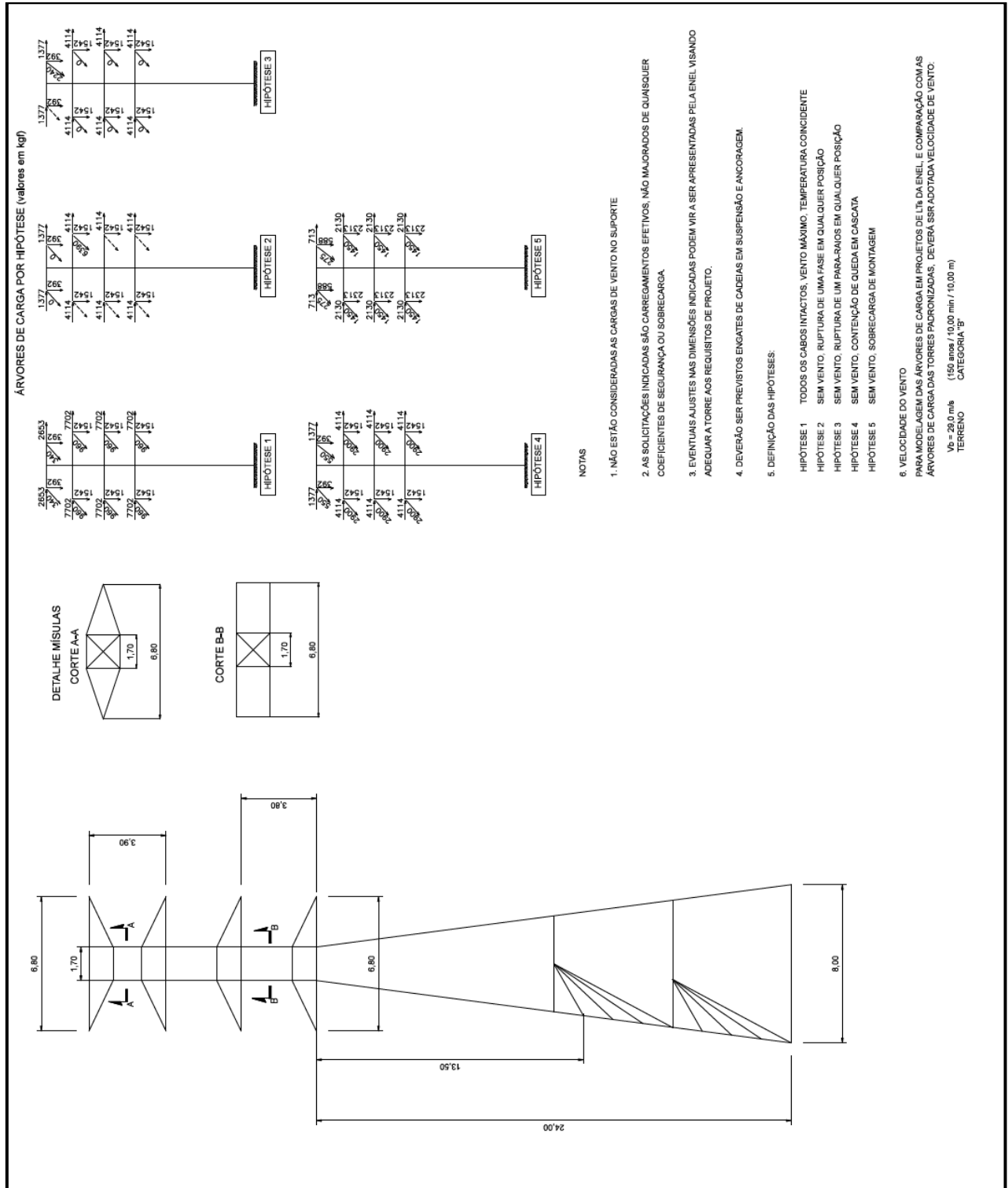



Torre T.10

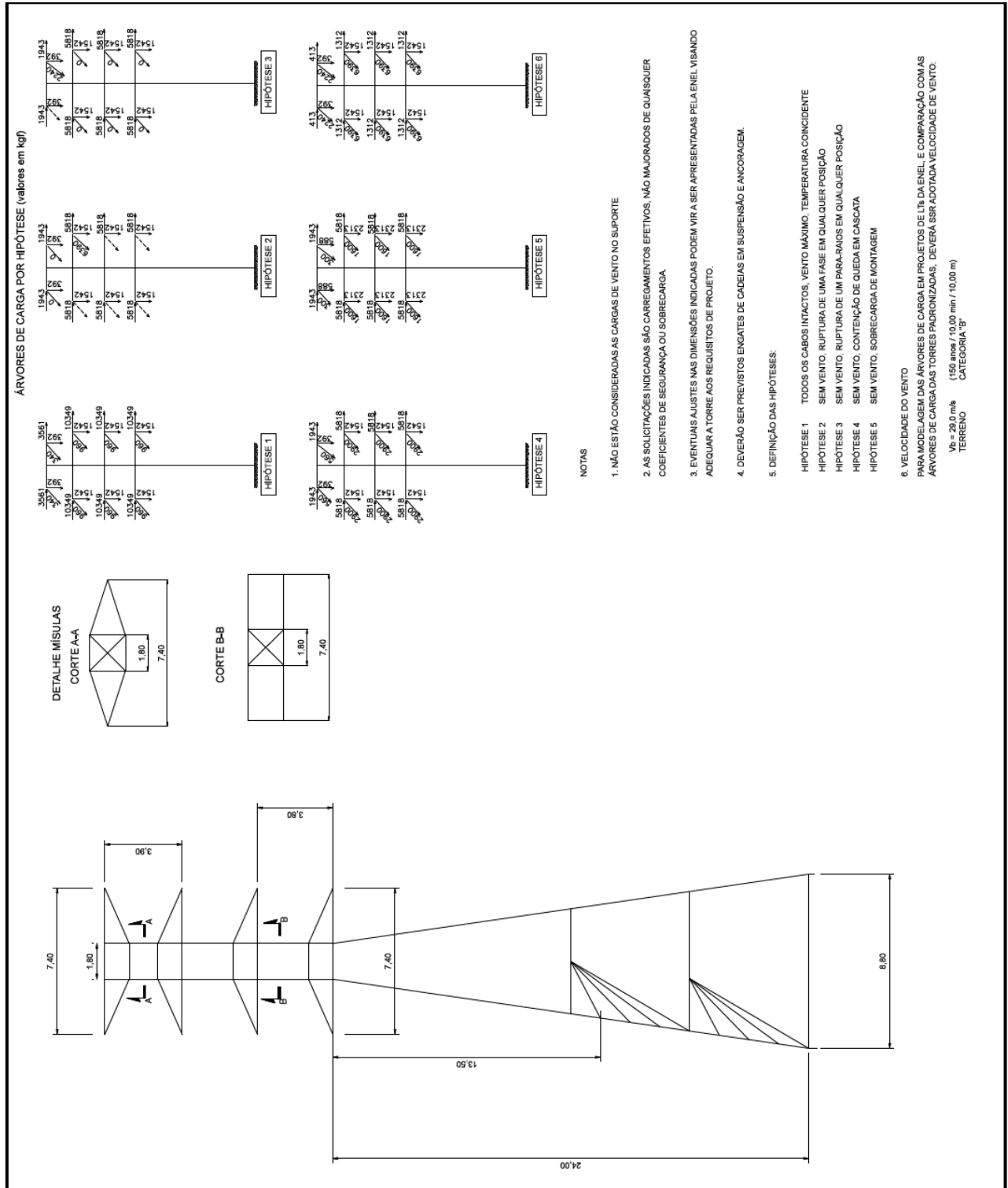

	GLOBAL STANDARD	Page 79 of 94
	LATTICE STEEL SUPPORTS FOR HIGH VOLTAGE LINES	GSCS001 Rev. 01 05/02/2024

### ANNEX C – LIST OF GLOBAL STANDARD CODES

GS Type Code	Designation
GSCS001/001	DF-1 25-15
GSCS001/002	DF-1 30-15
GSCS001/003	DF-1 30-23
GSCS001/004	DF-1 40-23
GSCS001/005	DF-1 50-23
GSCS001/006	DF-1 55-23
GSCS001/007	DF-2 30-15
GSCS001/008	DF-2 40-15
GSCS001/009	DF-2 40-23
GSCS001/010	DF-2 50-23
GSCS001/011	DF-2 55-23
GSCS001/012	DF-3 30-15
GSCS001/013	DF-3 40-23
GSCS001/014	DF-3 50-23
GSCS001/015	DG-1 30-15
GSCS001/016	DG-1 40-15
GSCS001/017	DG-2 30-15
GSCS001/018	DG-2 40-15
GSCS001/019	DG-2 40-23
GSCS001/020	DG-2 50-23
GSCS001/021	DG-3 30-15
GSCS001/022	DG-3 40-15
GSCS001/023	DG-3 40-23
GSCS001/024	DG-5 30-15
GSCS001/025	DG-5 30-23
GSCS001/026	DG-5 40-15
GSCS001/027	DG-5 40-23
GSCS001/028	DG-5 50-23
GSCS001/029	DL-0 30-15
GSCS001/030	DL-1 25-15
GSCS001/031	DL-1 30-15
GSCS001/032	DL-1 40-15
GSCS001/033	DL-1 40-23
GSCS001/034	DL-2 30-15

GS Type Code	Designation
GSCS001/035	DL-2 40-15
GSCS001/036	DL-2 40-23
GSCS001/037	DL-3 30-15
GSCS001/038	DL-3 40-23
GSCS001/039	DL-3 55-23
GSCS001/040	DM-0 25-15
GSCS001/041	DM-0 30-15
GSCS001/042	DM-1 30-15
GSCS001/043	DM-1 30-23
GSCS001/044	DM-1 40-15
GSCS001/045	DM-1 40-23
GSCS001/046	DM-1 50-23
GSCS001/047	DM-2 25-15
GSCS001/048	DM-2 30-15
GSCS001/049	DM-2 40-15
GSCS001/050	DM-2 40-23
GSCS001/051	DM-2 50-23
GSCS001/052	DM-3 25-15
GSCS001/053	DM-3 30-15
GSCS001/054	DM-3 40-23
GSCS001/055	DM-3 55-23
GSCS001/056	DM-4 30-15
GSCS001/057	DM-4 30-23
GSCS001/058	DM-4 40-23
GSCS001/059	DM-4 55-23
GSCS001/060	SF-1 30-15
GSCS001/061	SF-1 40-15
GSCS001/062	SF-1 40-23
GSCS001/063	SF-1 55-23
GSCS001/064	SF-2 30-15
GSCS001/065	SF-2 40-23
GSCS001/066	SF-3 30-15
GSCS001/067	SF-3 40-23
GSCS001/068	SF-3 55-23

	GLOBAL STANDARD	Page 80 of 94
	LATTICE STEEL SUPPORTS FOR HIGH VOLTAGE LINES	GSCS001 Rev. 01 05/02/2024

GS Type Code	Designation
GSCS001/069	SG-1 25-15
GSCS001/070	SG-1 30-15
GSCS001/071	SG-1 40-23
GSCS001/072	SG-1 50-23
GSCS001/073	SG-2 30-15
GSCS001/074	SG-2 40-15
GSCS001/075	SG-2 40-23
GSCS001/076	SG-2 50-23
GSCS001/077	SG-3 40-23
GSCS001/078	SG-5 30-15
GSCS001/079	SG-5 30-23
GSCS001/080	SG-5 40-23
GSCS001/081	SG-5 55-23
GSCS001/082	SL-0 30-15
GSCS001/083	SL-1 30-15
GSCS001/084	SL-1 40-15
GSCS001/085	SL-1 40-23
GSCS001/086	SL-2 30-15
GSCS001/087	SL-2 40-15
GSCS001/088	SL-2 50-23
GSCS001/089	SL-3 30-15
GSCS001/090	SL-3 40-23
GSCS001/091	SL-3 55-23
GSCS001/092	SM-0 25-15
GSCS001/093	SM-0 30-15
GSCS001/094	SM-0 40-15
GSCS001/095	SM-0 50-15
GSCS001/096	SM-1 30-15
GSCS001/097	SM-1 40-15
GSCS001/098	SM-1 40-23
GSCS001/099	SM-1 50-15
GSCS001/100	SM-1 50-23
GSCS001/101	SM-1 55-23
GSCS001/102	SM-2 30-15
GSCS001/103	SM-2 40-15
GSCS001/104	SM-2 40-23
GSCS001/105	SM-2 50-23

GS Type Code	Designation
GSCS001/106	SM-3 30-15
GSCS001/107	SM-3 40-15
GSCS001/108	SM-3 40-23
GSCS001/109	SM-3 50-15
GSCS001/110	SM-4 30-15
GSCS001/111	SM-4 40-23
GSCS001/112	SM-4 55-23
GSCS001/T1	TIPO T1
GSCS001/T2	TIPO T2
GSCS001/T3	TIPO T3
GSCS001/T4	TIPO T4
GSCS001/T5	TIPO T5
GSCS001/T6	TIPO T6
GSCS001/T7	TIPO T7
GSCS001/T8	TIPO T8
GSCS001/T9	TIPO T9
GSCS001/T10	TIPO T10





## ANNEX D – COMMON LIST OF LOCAL CODES

TAM Code	Country	GS Type Code	TAM Description
230399	BR	GSCS001/T1	TORRE AUTOPORTANTE METÁLICA, TIPO T1, GSCS001
230387	BR	GSCS001/T2	TORRE AUTOPORTANTE METÁLICA, TIPO T2, GSCS001
230390	BR	GSCS001/T3	TORRE AUTOPORTANTE METÁLICA, TIPO T3, GSCS001
230392	BR	GSCS001/T4	TORRE AUTOPORTANTE METÁLICA, TIPO T4, GSCS001
230391	BR	GSCS001/T5	TORRE AUTOPORTANTE METÁLICA, TIPO T5, GSCS001
230389	BR	GSCS001/T6	TORRE AUTOPORTANTE METÁLICA, TIPO T6, GSCS001
230388	BR	GSCS001/T7	TORRE AUTOPORTANTE METÁLICA, TIPO T7, GSCS001
230386	BR	GSCS001/T8	TORRE AUTOPORTANTE METÁLICA, TIPO T8, GSCS001
230385	BR	GSCS001/T9	TORRE AUTOPORTANTE METÁLICA, TIPO T9, GSCS001
230384	BR	GSCS001/T10	TORRE AUTOPORTANTE METÁLICA, TIPO T10, GSCS001
230591	ES	GSCS001/002	Apoyo LAT - DF-1 30-15 12m metálico de celosía, doble circuito, tipo F-1, cimentaciones separadas, 3 metros de distancia entre conductores, longitud mínima de cruceta de 1,5 metros y altura útil de 12 metros.
230593	ES	GSCS001/002	Apoyo LAT - DF-1 30-15 15m metálico de celosía, doble circuito, tipo F-1, cimentaciones separadas, 3 metros de distancia entre conductores, longitud mínima de cruceta de 1,5 metros y altura útil de 15 metros.
230597	ES	GSCS001/002	Apoyo LAT - DF-1 30-15 18m metálico de celosía, doble circuito, tipo F-1, cimentaciones separadas, 3 metros de distancia entre conductores, longitud mínima de cruceta de 1,5 metros y altura útil de 18 metros.
230600	ES	GSCS001/002	Apoyo LAT - DF-1 30-15 21m metálico de celosía, doble circuito, tipo F-1, cimentaciones separadas, 3 metros de distancia entre conductores, longitud mínima de cruceta de 1,5 metros y altura útil de 21 metros.
230598	ES	GSCS001/002	Apoyo LAT - DF-1 30-15 27m metálico de celosía, doble circuito, tipo F-1, cimentaciones separadas, 3 metros de distancia entre conductores, longitud mínima de cruceta de 1,5 metros y altura útil de 27 metros.
230601	ES	GSCS001/002	Apoyo LAT - DF-1 30-15 35m metálico de celosía, doble circuito, tipo F-1, cimentaciones separadas, 3 metros de distancia entre conductores, longitud mínima de cruceta de 1,5 metros y altura útil de 35 metros.
230599	ES	GSCS001/004	Apoyo LAT - DF-1 40-23 12m metálico de celosía, doble circuito, tipo F-1, cimentaciones separadas, 4 metros de distancia entre conductores, longitud mínima de cruceta de 2,3 metros y altura útil de 12 metros.
230604	ES	GSCS001/004	Apoyo LAT - DF-1 40-23 15m metálico de celosía, doble circuito, tipo F-1, cimentaciones separadas, 4 metros de distancia entre conductores, longitud mínima de cruceta de 2,3 metros y altura útil de 15 metros.
230606	ES	GSCS001/004	Apoyo LAT - DF-1 40-23 18m metálico de celosía, doble circuito, tipo F-1, cimentaciones separadas, 4 metros de distancia entre conductores, longitud mínima de cruceta de 2,3 metros y altura útil de 18 metros.
230605	ES	GSCS001/004	Apoyo LAT - DF-1 40-23 21m metálico de celosía, doble circuito, tipo F-1, cimentaciones separadas, 4 metros de distancia entre conductores, longitud mínima de cruceta de 2,3 metros y altura útil de 21 metros.
230603	ES	GSCS001/004	Apoyo LAT - DF-1 40-23 27m metálico de celosía, doble circuito, tipo F-1, cimentaciones separadas, 4 metros de distancia entre conductores, longitud mínima de cruceta de 2,3 metros y altura útil de 27 metros.
230607	ES	GSCS001/004	Apoyo LAT - DF-1 40-23 35m metálico de celosía, doble circuito, tipo F-1, cimentaciones separadas, 4 metros de distancia entre conductores, longitud mínima de cruceta de 2,3 metros y altura útil de 35 metros.
230730	ES	GSCS001/002	Apoyo LAT - DF-1 CON 30-15 15m metálico de celosía, doble circuito, tipo F-1, de conversión, cimentaciones separadas, 3 metros de distancia entre conductores, longitud mínima de cruceta de 1,5 metros y altura útil de 15 metros.
230613	ES	GSCS001/002	Apoyo LAT - DF-1 CON 30-15 18m metálico de celosía, doble circuito, tipo F-1, de conversión, cimentaciones separadas, 3 metros de distancia entre conductores, longitud mínima de cruceta de 1,5 metros y altura útil de 18 metros.
230609	ES	GSCS001/002	Apoyo LAT - DF-1 CON 30-15 21m metálico de celosía, doble circuito, tipo F-1, de conversión, cimentaciones separadas, 3 metros de distancia entre conductores, longitud mínima de cruceta de 1,5 metros y altura útil de 21 metros.
230608	ES	GSCS001/005	Apoyo LAT - DF-1 CON 50-23 15m metálico de celosía, doble circuito, tipo F-1, de conversión, cimentaciones separadas, 5 metros de distancia entre conductores, longitud mínima de cruceta de 2,3 metros y altura útil de 15 metros.
230612	ES	GSCS001/005	Apoyo LAT - DF-1 CON 50-23 18m metálico de celosía, doble circuito, tipo F-1, de conversión, cimentaciones separadas, 5 metros de distancia entre conductores, longitud mínima de cruceta de 2,3 metros y altura útil de 18 metros.
230731	ES	GSCS001/005	Apoyo LAT - DF-1 CON 50-23 21m metálico de celosía, doble circuito, tipo F-1, de conversión, cimentaciones separadas, 5 metros de distancia entre conductores, longitud mínima de cruceta de 2,3 metros y altura útil de 21 metros.
230647	ES	GSCS001/002	Apoyo LAT - DF-1 ENT 30-15 15m metálico de celosía, doble circuito, tipo F-1, de entronque, cimentaciones separadas, 3 metros de distancia entre conductores, longitud mínima de cruceta de 1,5 metros y altura útil de 15 metros. 3 Crucetas adicionales de 2,6 metros.
230652	ES	GSCS001/002	Apoyo LAT - DF-1 ENT 30-15 21m metálico de celosía, doble circuito, tipo F-1, de entronque, cimentaciones separadas, 3 metros de distancia entre conductores, longitud mínima de cruceta de 1,5 metros y altura útil de 21 metros. 3 Crucetas adicionales de 2,6 metros.
230648	ES	GSCS001/002	Apoyo LAT - DF-1 ENT 30-15 27m metálico de celosía, doble circuito, tipo F-1, de entronque, cimentaciones separadas, 3 metros de distancia entre conductores, longitud mínima de cruceta de 1,5 metros y altura útil de 27 metros. 3 Crucetas adicionales de 2,6 metros.
230650	ES	GSCS001/004	Apoyo LAT - DF-1 ENT 40-23 15m metálico de celosía, doble circuito, tipo F-1, de entronque, cimentaciones separadas, 4 metros de distancia entre conductores, longitud mínima de cruceta de 2,3 metros y altura útil de 15 metros. 3 Crucetas adicionales de 3,5 metros.
230654	ES	GSCS001/004	Apoyo LAT - DF-1 ENT 40-23 21m metálico de celosía, doble circuito, tipo F-1, de entronque, cimentaciones separadas, 4 metros de distancia entre conductores, longitud mínima de cruceta de 2,3 metros y altura útil de 21 metros. 3 Crucetas adicionales de 3,5 metros.













TAM Code	Country	GS Type Code	TAM Description
230535	ES	GSCS001/056	Apoyo LAT - DM-4 30-15 18m metálico de celosía, doble circuito, tipo M-4, cimentaciones separadas, 3 metros de distancia entre conductores, longitud mínima de cruceta de 1,5 metros y altura útil de 18 metros.
230534	ES	GSCS001/056	Apoyo LAT - DM-4 30-15 21m metálico de celosía, doble circuito, tipo M-4, cimentaciones separadas, 3 metros de distancia entre conductores, longitud mínima de cruceta de 1,5 metros y altura útil de 21 metros.
230530	ES	GSCS001/056	Apoyo LAT - DM-4 30-15 24m metálico de celosía, doble circuito, tipo M-4, cimentaciones separadas, 3 metros de distancia entre conductores, longitud mínima de cruceta de 1,5 metros y altura útil de 24 metros.
230536	ES	GSCS001/056	Apoyo LAT - DM-4 30-15 31m metálico de celosía, doble circuito, tipo M-4, cimentaciones separadas, 3 metros de distancia entre conductores, longitud mínima de cruceta de 1,5 metros y altura útil de 31 metros.
230541	ES	GSCS001/056	Apoyo LAT - DM-4 30-15 39m metálico de celosía, doble circuito, tipo M-4, cimentaciones separadas, 3 metros de distancia entre conductores, longitud mínima de cruceta de 1,5 metros y altura útil de 39 metros.
230539	ES	GSCS001/058	Apoyo LAT - DM-4 40-23 12m metálico de celosía, doble circuito, tipo M-4, cimentaciones separadas, 4 metros de distancia entre conductores, longitud mínima de cruceta de 2,3 metros y altura útil de 12 metros.
230550	ES	GSCS001/058	Apoyo LAT - DM-4 40-23 15m metálico de celosía, doble circuito, tipo M-4, cimentaciones separadas, 4 metros de distancia entre conductores, longitud mínima de cruceta de 2,3 metros y altura útil de 15 metros.
230538	ES	GSCS001/058	Apoyo LAT - DM-4 40-23 18m metálico de celosía, doble circuito, tipo M-4, cimentaciones separadas, 4 metros de distancia entre conductores, longitud mínima de cruceta de 2,3 metros y altura útil de 18 metros.
230540	ES	GSCS001/058	Apoyo LAT - DM-4 40-23 21m metálico de celosía, doble circuito, tipo M-4, cimentaciones separadas, 4 metros de distancia entre conductores, longitud mínima de cruceta de 2,3 metros y altura útil de 21 metros.
230542	ES	GSCS001/058	Apoyo LAT - DM-4 40-23 24m metálico de celosía, doble circuito, tipo M-4, cimentaciones separadas, 4 metros de distancia entre conductores, longitud mínima de cruceta de 2,3 metros y altura útil de 24 metros.
230544	ES	GSCS001/058	Apoyo LAT - DM-4 40-23 31m metálico de celosía, doble circuito, tipo M-4, cimentaciones separadas, 4 metros de distancia entre conductores, longitud mínima de cruceta de 2,3 metros y altura útil de 31 metros.
230546	ES	GSCS001/058	Apoyo LAT - DM-4 40-23 39m metálico de celosía, doble circuito, tipo M-4, cimentaciones separadas, 4 metros de distancia entre conductores, longitud mínima de cruceta de 2,3 metros y altura útil de 39 metros.
230632	ES	GSCS001/056	Apoyo LAT - DM-4 ENT 30-15 15m metálico de celosía, doble circuito, tipo M-4, de entronque, cimentaciones separadas, 3 metros de distancia entre conductores, longitud mínima de cruceta de 1,5 metros y altura útil de 15 metros. 3 Crucetas adicionales de 2,6 metros.
230633	ES	GSCS001/056	Apoyo LAT - DM-4 ENT 30-15 21m metálico de celosía, doble circuito, tipo M-4, de entronque, cimentaciones separadas, 3 metros de distancia entre conductores, longitud mínima de cruceta de 1,5 metros y altura útil de 21 metros. 3 Crucetas adicionales de 2,6 metros.
230636	ES	GSCS001/058	Apoyo LAT - DM-4 ENT 40-23 15m metálico de celosía, doble circuito, tipo M-4, de entronque, cimentaciones separadas, 4 metros de distancia entre conductores, longitud mínima de cruceta de 2,3 metros y altura útil de 15 metros. 3 Crucetas adicionales de 3,5 metros.
230638	ES	GSCS001/058	Apoyo LAT - DM-4 ENT 40-23 21m metálico de celosía, doble circuito, tipo M-4, de entronque, cimentaciones separadas, 4 metros de distancia entre conductores, longitud mínima de cruceta de 2,3 metros y altura útil de 21 metros. 3 Crucetas adicionales de 3,5 metros.
230387	ES	GSCS001/060	Apoyo LAT - SF-1 30-15 12m metálico de celosía, simple circuito, tipo F-1, cimentaciones separadas, 3 metros de distancia entre conductores, longitud mínima de cruceta de 1,5 metros y altura útil de 12 metros.
230376	ES	GSCS001/060	Apoyo LAT - SF-1 30-15 15m metálico de celosía, simple circuito, tipo F-1, cimentaciones separadas, 3 metros de distancia entre conductores, longitud mínima de cruceta de 1,5 metros y altura útil de 15 metros.
230382	ES	GSCS001/060	Apoyo LAT - SF-1 30-15 18m metálico de celosía, simple circuito, tipo F-1, cimentaciones separadas, 3 metros de distancia entre conductores, longitud mínima de cruceta de 1,5 metros y altura útil de 18 metros.
230377	ES	GSCS001/060	Apoyo LAT - SF-1 30-15 21m metálico de celosía, simple circuito, tipo F-1, cimentaciones separadas, 3 metros de distancia entre conductores, longitud mínima de cruceta de 1,5 metros y altura útil de 21 metros.
230379	ES	GSCS001/060	Apoyo LAT - SF-1 30-15 27m metálico de celosía, simple circuito, tipo F-1, cimentaciones separadas, 3 metros de distancia entre conductores, longitud mínima de cruceta de 1,5 metros y altura útil de 27 metros.
230380	ES	GSCS001/060	Apoyo LAT - SF-1 30-15 35m metálico de celosía, simple circuito, tipo F-1, cimentaciones separadas, 3 metros de distancia entre conductores, longitud mínima de cruceta de 1,5 metros y altura útil de 35 metros.
230384	ES	GSCS001/062	Apoyo LAT - SF-1 40-23 12m metálico de celosía, simple circuito, tipo F-1, cimentaciones separadas, 4 metros de distancia entre conductores, longitud mínima de cruceta de 2,3 metros y altura útil de 12 metros.



TAM Code	Country	GS Type Code	TAM Description
230386	ES	GSCS001/062	Apoyo LAT - SF-1 40-23 15m metálico de celosía, simple circuito, tipo F-1, cimentaciones separadas, 4 metros de distancia entre conductores, longitud mínima de cruceta de 2,3 metros y altura útil de 15 metros.
230392	ES	GSCS001/062	Apoyo LAT - SF-1 40-23 18m metálico de celosía, simple circuito, tipo F-1, cimentaciones separadas, 4 metros de distancia entre conductores, longitud mínima de cruceta de 2,3 metros y altura útil de 18 metros.
230383	ES	GSCS001/062	Apoyo LAT - SF-1 40-23 21m metálico de celosía, simple circuito, tipo F-1, cimentaciones separadas, 4 metros de distancia entre conductores, longitud mínima de cruceta de 2,3 metros y altura útil de 21 metros.
230385	ES	GSCS001/062	Apoyo LAT - SF-1 40-23 27m metálico de celosía, simple circuito, tipo F-1, cimentaciones separadas, 4 metros de distancia entre conductores, longitud mínima de cruceta de 2,3 metros y altura útil de 27 metros.
230391	ES	GSCS001/062	Apoyo LAT - SF-1 40-23 35m metálico de celosía, simple circuito, tipo F-1, cimentaciones separadas, 4 metros de distancia entre conductores, longitud mínima de cruceta de 2,3 metros y altura útil de 35 metros.
230388	ES	GSCS001/060	Apoyo LAT - SF-1 CON 30-15 15m metálico de celosía, simple circuito, tipo F-1, de conversión, cimentaciones separadas, 3 metros de distancia entre conductores, longitud mínima de cruceta de 1,5 metros y altura útil de 15 metros.
230390	ES	GSCS001/060	Apoyo LAT - SF-1 CON 30-15 18m metálico de celosía, simple circuito, tipo F-1, de conversión, cimentaciones separadas, 3 metros de distancia entre conductores, longitud mínima de cruceta de 1,5 metros y altura útil de 18 metros.
230389	ES	GSCS001/060	Apoyo LAT - SF-1 CON 30-15 21m metálico de celosía, simple circuito, tipo F-1, de conversión, cimentaciones separadas, 3 metros de distancia entre conductores, longitud mínima de cruceta de 1,5 metros y altura útil de 21 metros.
230393	ES	GSCS001/063	Apoyo LAT - SF-1 CON 55-23 15m metálico de celosía, simple circuito, tipo F-1, de conversión, cimentaciones separadas, 5,5 metros de distancia entre conductores, longitud mínima de cruceta de 2,3 metros y altura útil de 15 metros.
230396	ES	GSCS001/063	Apoyo LAT - SF-1 CON 55-23 18m metálico de celosía, simple circuito, tipo F-1, de conversión, cimentaciones separadas, 5,5 metros de distancia entre conductores, longitud mínima de cruceta de 2,3 metros y altura útil de 18 metros.
230394	ES	GSCS001/063	Apoyo LAT - SF-1 CON 55-23 21m metálico de celosía, simple circuito, tipo F-1, de conversión, cimentaciones separadas, 5,5 metros de distancia entre conductores, longitud mínima de cruceta de 2,3 metros y altura útil de 21 metros.
230398	ES	GSCS001/066	Apoyo LAT - SF-3 30-15 12m metálico de celosía, simple circuito, tipo F-3, cimentaciones separadas, 3 metros de distancia entre conductores, longitud mínima de cruceta de 1,5 metros y altura útil de 12 metros.
230395	ES	GSCS001/066	Apoyo LAT - SF-3 30-15 15m metálico de celosía, simple circuito, tipo F-3, cimentaciones separadas, 3 metros de distancia entre conductores, longitud mínima de cruceta de 1,5 metros y altura útil de 15 metros.
230403	ES	GSCS001/066	Apoyo LAT - SF-3 30-15 18m metálico de celosía, simple circuito, tipo F-3, cimentaciones separadas, 3 metros de distancia entre conductores, longitud mínima de cruceta de 1,5 metros y altura útil de 18 metros.
230397	ES	GSCS001/066	Apoyo LAT - SF-3 30-15 24m metálico de celosía, simple circuito, tipo F-3, cimentaciones separadas, 3 metros de distancia entre conductores, longitud mínima de cruceta de 1,5 metros y altura útil de 24 metros.
230399	ES	GSCS001/066	Apoyo LAT - SF-3 30-15 31m metálico de celosía, simple circuito, tipo F-3, cimentaciones separadas, 3 metros de distancia entre conductores, longitud mínima de cruceta de 1,5 metros y altura útil de 31 metros.
230416	ES	GSCS001/066	Apoyo LAT - SF-3 30-15 39m metálico de celosía, simple circuito, tipo F-3, cimentaciones separadas, 3 metros de distancia entre conductores, longitud mínima de cruceta de 1,5 metros y altura útil de 39 metros.
230402	ES	GSCS001/067	Apoyo LAT - SF-3 40-23 12m metálico de celosía, simple circuito, tipo F-3, cimentaciones separadas, 4 metros de distancia entre conductores, longitud mínima de cruceta de 2,3 metros y altura útil de 12 metros.
230401	ES	GSCS001/067	Apoyo LAT - SF-3 40-23 15m metálico de celosía, simple circuito, tipo F-3, cimentaciones separadas, 4 metros de distancia entre conductores, longitud mínima de cruceta de 2,3 metros y altura útil de 15 metros.
230405	ES	GSCS001/067	Apoyo LAT - SF-3 40-23 18m metálico de celosía, simple circuito, tipo F-3, cimentaciones separadas, 4 metros de distancia entre conductores, longitud mínima de cruceta de 2,3 metros y altura útil de 18 metros.
230404	ES	GSCS001/067	Apoyo LAT - SF-3 40-23 24m metálico de celosía, simple circuito, tipo F-3, cimentaciones separadas, 4 metros de distancia entre conductores, longitud mínima de cruceta de 2,3 metros y altura útil de 24 metros.
230406	ES	GSCS001/067	Apoyo LAT - SF-3 40-23 31m metálico de celosía, simple circuito, tipo F-3, cimentaciones separadas, 4 metros de distancia entre conductores, longitud mínima de cruceta de 2,3 metros y altura útil de 31 metros.
230410	ES	GSCS001/067	Apoyo LAT - SF-3 40-23 39m metálico de celosía, simple circuito, tipo F-3, cimentaciones separadas, 4 metros de distancia entre conductores, longitud mínima de cruceta de 2,3 metros y altura útil de 39 metros.













	GLOBAL STANDARD	Page 94 of 94
	LATTICE STEEL SUPPORTS FOR HIGH VOLTAGE LINES	GSCS001 Rev. 01 05/02/2024

TAM Code	Country	GS Type Code	TAM Description
230811	ES	GSCS001/075	Apoyo LAT metálico de celosía, simple circuito, tipo G-2, monobloque, 4 metros de distancia entre conductores, longitud mínima de cruceta de 1,5 metros y altura útil de 10 metros.
230832	ES	GSCS001/079	Apoyo LAT metálico de celosía, simple circuito, tipo G-5, cimentaciones separadas, 3 metros de distancia entre conductores, longitud mínima de cruceta de 1,5 metros y altura útil de 27 metros
230833	ES	GSCS001/080	Apoyo LAT metálico de celosía, simple circuito, tipo G-5, cimentaciones separadas, 4 metros de distancia entre conductores, longitud mínima de cruceta de 2,3 metros y altura útil de 27 metros
230807	ES	GSCS001/087	Apoyo LAT metálico de celosía, simple circuito, tipo L-2, monobloque, 4 metros de distancia entre conductores, longitud mínima de cruceta de 1,5 metros y altura útil de 18 metros.
230806	ES	GSCS001/087	Apoyo LAT metálico de celosía, simple circuito, tipo L-2, monobloque, 4 metros de distancia entre conductores, longitud mínima de cruceta de 1,5 metros y altura útil de 24 metros.
230805	ES	GSCS001/087	Apoyo LAT metálico de celosía, simple circuito, tipo L-2, monobloque, 4 metros de distancia entre conductores, longitud mínima de cruceta de 1,5 metros y altura útil de 27 metros.
230803	ES	GSCS001/087	Apoyo LAT metálico de celosía, simple circuito, tipo L-2, monobloque, 4 metros de distancia entre conductores, longitud mínima de cruceta de 1,5 metros y altura útil de 31 metros.
230804	ES	GSCS001/103	Apoyo LAT metálico de celosía, simple circuito, tipo M-2, monobloque, 4 metros de distancia entre conductores, longitud mínima de cruceta de 1,5 metros y altura útil de 10 metros.
230802	ES	GSCS001/103	Apoyo LAT metálico de celosía, simple circuito, tipo M-2, monobloque, 4 metros de distancia entre conductores, longitud mínima de cruceta de 1,5 metros y altura útil de 24 metros.